

PROJECT: 15B.13.28

CONTRACT:



VICINITY MAP

STATE OF NORTH CAROLINA
DIVISION OF HIGHWAYS

NEW HANOVER COUNTY

LOCATION: NEW HANOVER BRIDGE #13, OVER THE CAPE FEAR RIVER.

TYPE OF WORK: NEW STANDBY GENERATOR

STATE	STATE PROJECT REFERENCE NO.	SHEET NO.	TOTAL SHEETS
N.C.	15B.13.28	1	16
STATE PROJ. NO.	F.A. PROJ. NO.	DESCRIPTION	

LIST OF DRAWINGS

DRAWING NO.	SHEET NAME
1	TITLE SHEET
2 (E1)	ELECTRICAL PLAN AND ELEVATION
3 (E2)	ELECTRICAL NOTES - 1
4 (E3)	ELECTRICAL NOTES - 2
5 (E4)	GENERATOR PAD DETAILS - 1
6 (E5)	GENERATOR PAD DETAILS - 2
7 (E6)	GENERATOR PAD DETAILS - 3
8 (E7)	THREE LINE DIAGRAM
9 (E8)	CONTROL HOUSE
10 (E9)	CONTROL CONSOLE
11 (E10)	CONTROL CIRCUITS - EXISTING
12 (E11)	CONTROL CIRCUITS - NEW
13 (E12)	PANELBOARD SCHEDULE AND CIRCUITS
14 (E13)	CONDUIT SCHEDULE - 1
15 (E14)	CONDUIT SCHEDULE - 2
16 (E15)	ELECTRICAL EQUIPMENT LIST

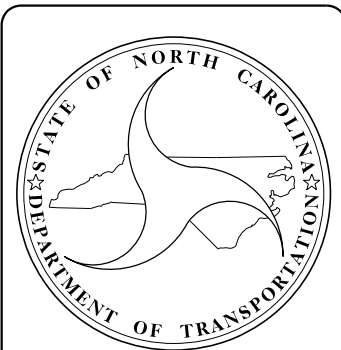

DESIGN DATA

PROJECT LENGTH

Prepared in the Office of:
DEPARTMENT OF TRANSPORTATION
DIVISION OF HIGHWAYS
STRUCTURES MANAGEMENT UNIT - PRESERVATION & REPAIR GROUP
1000 BIRCH RIDGE DR. RALEIGH, N.C. 27610

RICK NELSON, P.E.

2012 STANDARD SPECIFICATIONS

LETTING DATE:

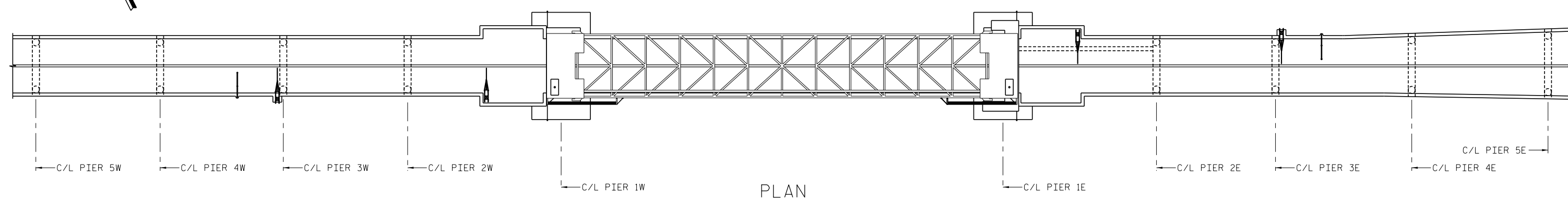

PLAN
SCALE: 1" = 50'-0"

SUMMARY OF QUANTITIES

ITEM NUMBER	SEC. NO.	QUANTITY	UNIT	DESCRIPTION
0000100000-N	800	LUMP SUM		MOBILIZATION
1220000000-E	545	140	TON	INCIDENTAL STONE BASE
	SP	LUMP SUM		BRIDGE ELECTRICAL WORK

- CONTROL HOUSE**
- REMOVE EXISTING 600A AND 100A TRANSFER SWITCH COMPONENTS FROM CABINETS
 - RECONFIGURE SWITCHES AND INDICATOR LIGHTS IN THE EXISTING CONTROL ROOM CONSOLE
 - INTERFACE NEW AUTOMATIC TRANSFER SWITCH, GENERATOR, AND LOAD BANK WITH EXISTING CONTROL SYSTEM
 - PERFORM PLC (AND HMI) PROGRAMMABLE CHANGES FOR NEW EQUIPMENT

- EXISTING 300KW AND 15KW GENERATORS**
- REMOVE AND DISPOSE OF FUEL AND FUEL TANKS
 - ELECTRICALLY DISCONNECT GENERATORS AND REMOVE WIRING
 - ABANDON EXISTING GENERATORS IN PLACE

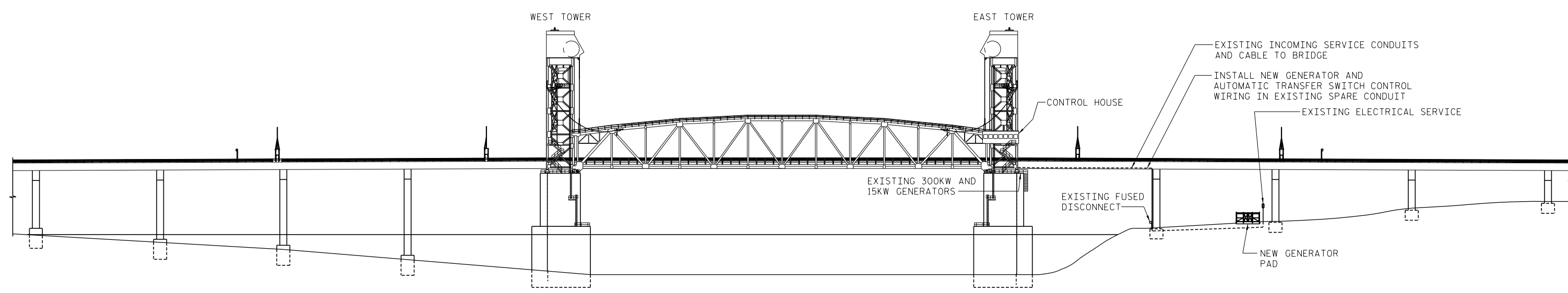

ELEVATION
SCALE: 1" = 50'-0"

- INCOMING SERVICE**
- COORDINATE SERVICE REQUIREMENTS WITH UTILITY
 - PERFORM SITE EXCAVATION FOR GENERATOR PAD, PROVIDE AND INSTALL STONE BALLAST FOR GENERATOR PAD AREA AND ACCESS RAMP
 - INSTALL NEW GENERATOR PAD, FENCING, AND GROUNDING SYSTEM
 - INSTALL NEW GENERATOR, AUTOMATIC TRANSFER SWITCH, PANELBOARD/TRANSFORMER, LOAD BANK, AND SERVICE DISCONNECT SWITCH
 - INSTALL NEW ELECTRICAL SERVICE FROM EXISTING METER POLE INCLUDING CONDUIT, TRENCHING, PULL BOX, AND CABLE
 - INSTALL NEW CONDUIT AND WIRING FOR GENERATOR AND AUTOMATIC TRANSFER SWITCH

GENERAL NOTES:

1. THIS DRAWING INDICATES THE LOCATIONS AND GENERAL DESCRIPTIONS OF THE MAJOR ITEMS OF WORK. CONTRACTOR SHALL REFERENCE THE PLANS AND SPECIFICATIONS FOR COMPLETE DESCRIPTIONS OF REQUIRED WORK AND MATERIALS.
2. UNLESS OTHERWISE DIRECTED BY NCDOT, ALL REMOVALS BECOME PROPERTY OF THE CONTRACTOR.

PROJECT NO. 15B.13.28
NEW HANOVER COUNTY
 STATION: _____

SHEET 2 OF 16

STATE OF NORTH CAROLINA
 DEPARTMENT OF TRANSPORTATION
 RALEIGH

CAPE FEAR MEMORIAL
 LIFT BRIDGE
 ELECTRICAL PLAN
 AND ELEVATION

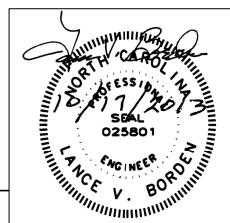

DRAWN BY : RLR DATE : 10/17/2013
 CHECKED BY : JGS DATE : 10/17/2013

10/18/2013 10:23:05 AM
 P:\2986.11\CADD\Electrical\2-E1-ELECTRICAL PLAN AND ELEVATION.dgn

DWG NUMBER	TOTAL DWGS
E1	16

REVISIONS						SHEET NO.
NO.	BY:	DATE:	NO.	BY:	DATE:	TOTAL SHEETS
1			3			16
2			4			

ELECTRICAL NOTES:

ALL WORK SHALL BE PERFORMED IN ACCORDANCE WITH THE NATIONAL ELECTRICAL CODE (2011 EDITION) AND WITH THE 2007 2ND EDITION OF THE AASHTO LRFD "MOVABLE HIGHWAY BRIDGE DESIGN SPECIFICATIONS."

ALL EQUIPMENT, RACEWAYS, WIRING, ETC. SHALL BE INSTALLED IN A NEAT AND WORKMAN LIKE MANNER IN ACCORDANCE WITH NECA 1 (STANDARD PRACTICE OF GOOD WORKMANSHIP IN ELECTRICAL CONSTRUCTION) AND WITHOUT VIOLATING ANY REQUIRED CLEAR WORKING SPACE (NEC 110.26).

IN NO WAY SHALL THESE PLANS BE INTERPRETED AS REQUIRING A VIOLATION OF THE NATIONAL ELECTRICAL CODE OR ANY OTHER APPLICABLE FEDERAL, STATE, OR LOCAL CODE OR REGULATION. IN ANY CASE OF DISPUTE BETWEEN THESE PLANS AND THE NATIONAL ELECTRICAL CODE, THE MORE STRINGENT REQUIREMENT SHALL GOVERN.

THE INSTALLATION OF ALL EQUIPMENT AND MATERIALS SHALL COMPLY WITH THEIR RESPECTIVE MANUFACTURE'S RECOMMENDATIONS AND INSTALLATION PROCEDURES.

THE CONTRACTOR IS EXPECTED TO DELIVER A COMPLETE, WORKING, AND SAFE ELECTRICAL SYSTEM.

VARIATIONS FROM THESE PLANS MUST BE SUBMITTED TO THE ENGINEER FOR APPROVAL. ALL CHANGES SHALL BE REFLECTED IN THE AS-BUILT DRAWINGS.

IN ADDITION TO THE MATERIALS, COMPONENTS, AND EQUIPMENT SHOWN ON THE PLANS, PROVIDE ALL RACEWAYS, JUNCTION AND PULL BOXES, FITTINGS, CONDUCTORS, CONNECTORS, AND OTHER ITEMS REQUIRED TO PROVIDE A COMPLETE, FUNCTIONAL, AND SAFE INSTALLATION.

THE CONTRACTOR IS REQUIRED TO COORDINATE WITH LOCAL ELECTRIC UTILITY COMPANY FOR ELECTRIC SERVICE CONNECTIONS AND INSTALLATION OF NEW EQUIPMENT.

THE CONTRACTOR SHALL INVESTIGATE AND/OR VERIFY THE LOCATIONS OF ALL EXISTING FACILITIES, ABOVE GROUND AND UNDERGROUND, PRIOR TO CONSTRUCTION. ANY DAMAGE TO EXISTING FACILITIES SHALL BE REPAIRED BY THE CONTRACTOR AS DIRECTED BY THE ENGINEER AT NO ADDITIONAL COST.

THE CONTRACTOR SHALL CAREFULLY TRACE, LOCATE, IDENTIFY, AND DOCUMENT ALL EXISTING EQUIPMENT, CONDUCTORS, RACEWAYS, AND OTHER ITEMS WHICH ARE EXISTING AND TO REMAIN IN PLACE, BE RE-ROUTED, OR BE RELOCATED. THE CONTRACTOR SHALL EXERCISE CARE NOT TO DAMAGE OR OTHERWISE DISTURB ANY ITEMS WHICH ARE EXISTING AND TO REMAIN IN PLACE.

LOCATIONS OF CONDUIT, CABLES, WIRING, AND OTHER EQUIPMENT SHOWN ON THE CONTRACT PLANS ARE DIAGRAMMATIC ONLY. EXACT LOCATIONS SHALL BE DETERMINED IN THE FIELD BY THE CONTRACTOR AND SUBJECT TO APPROVAL BY THE ENGINEER.

THE CONTRACTOR SHALL BEAR FULL RESPONSIBILITY FOR VERIFICATION OF ALL RELEVANT DIMENSIONS, EQUIPMENT SPECIFICATIONS, ELECTRICAL LOADS, CIRCUIT LOADS, AND SIMILAR INFORMATION PRIOR TO PURCHASE AND/OR FABRICATION OF EQUIPMENT OR MATERIALS. EQUIPMENT RATINGS, AND/OR WIRE SIZES SHOWN ON THE PLANS SHALL BE INCREASED WHERE REQUIRED BY THE LOADS SERVED.

ALL EQUIPMENT, RACEWAYS, WIRING, ETC. SHOWN ON THESE PLANS, OR OTHERWISE REQUIRED, SHALL BE NEW UNLESS SPECIFICALLY NOTED OTHERWISE.

E NUMBERS IN PARENTHESES, (EXXX), ASSOCIATED WITH EQUIPMENT REFER TO ITEM NUMBERS IN THE EQUIPMENT SCHEDULE.

THE CONTRACTOR IS RESPONSIBLE FOR SUPPLYING ANY TEMPORARY POWER REQUIRED TO SUPPORT BRIDGE OPERATIONS DURING CONSTRUCTION AND TO SUPPORT THE OVERALL CONSTRUCTION EFFORT.

WHERE DETAILS ARE NOT PROVIDED OR FULLY DEVELOPED, THE CONTRACTOR SHALL PROVIDE THE ADDITIONAL DETAIL DEVELOPMENT NECESSARY TO PROVIDE AND SUBMIT LAYOUT DRAWINGS AND SHOP DRAWINGS FOR REVIEW.

SUBSTITUTION OF MATERIALS:

REFERENCE TO A SPECIFIC MANUFACTURER, BRAND, MODEL, OR CATALOG NUMBER IS INTENDED TO DESCRIBE THE QUALITY AND CHARACTERISTICS OF THE MATERIAL REFERENCED, AND SHALL NOT BE INTERPRETED AS EXCLUDING EQUIVALENT PRODUCTS BY OTHER MANUFACTURERS. ALL PROPOSED SUBSTITUTIONS SHALL BE SUBMITTED TO THE ENGINEER FOR APPROVAL.

ARC FLASH HAZARD

PROVIDE ARC FLASH HAZARD LABELS FOR ALL ELECTRICAL ENCLOSURES AND TERMINAL CABINETS IN COMPLIANCE WITH THE ARC FLASH SAFETY REQUIREMENTS OF NFPA 70 AND NFPA 70E.

WIRING METHODS AND MATERIALS

UNLESS EXPLICITLY INDICATED OTHERWISE, ONLY THE FOLLOWING WIRING METHODS ARE PERMITTED:

- (A) ALL LOCATIONS
 - 1. PVC COATED STEEL RIGID METAL CONDUIT (RMC)
 - 2. LIQUIDTIGHT FLEXIBLE METAL CONDUIT (LFMC)
- (B) INSIDE THE EXISTING OPERATOR'S HOUSE AND ON THE ASSOCIATED TOWER PIER
 - 1. ANY METHOD PERMITTED IN (A)
 - 2. STEEL RIGID METAL CONDUIT (RMC)
 - 3. PVC JACKETED TYPE MC OR TC CABLES IN EXISTING ALUMINUM CABLE TRAY

ALL CONDUIT CONNECTIONS TO MOTORS AND SIMILAR EQUIPMENT SHALL BE MADE WITH FLEXIBLE CONDUIT. LENGTH OF FLEXIBLE CONDUIT SHALL BE NOT LESS THAN 18 INCHES BUT NOT MORE THAN 36 INCHES.

ALUMINUM BOXES, ENCLOSURES, FIXTURES, ETC. SHALL BE ISOLATED FROM CONCRETE AND/OR STRUCTURAL STEEL WITH NEOPRENE SHIMS OF 1/8 INCH MINIMUM THICKNESS. GALVANIZED CONDUITS, BOXES, ENCLOSURES, FIXTURES, ETC. SHALL BE ISOLATED FROM UNPAINTED STEEL WITH SIMILAR NEOPRENE SHIMS.

RIGID CONDUITS SHALL BE SUPPORTED WITHIN 18 INCHES OF ALL TERMINATIONS AND AT REGULAR INTERVALS NOT TO EXCEED 6 FEET.

ALL CONDUIT CONNECTIONS TO BOXES AND ENCLOSURES WHICH DO NOT HAVE INTEGRAL THREADED HUBS SHALL UTILIZE WEATHERPROOF GROUNDING TYPE HUBS OR CONNECTIONS. ALL HUBS AND CONNECTORS SHALL HAVE INSULATED THROATS OR BE PROVIDED WITH INSULATED BUSHINGS.

ANY CONDUIT ROUTINGS SHOWN ON THESE PLANS ARE CONCEPTUAL ONLY. ACTUAL ROUTINGS SHALL BE DETERMINED BY THE CONTRACTOR BASED ON ACTUAL CONDITIONS AND SUBMITTED TO THE ENGINEER FOR APPROVAL.

ALL CONDUCTORS SHALL BE STRANDED COPPER TYPE XHHW-2, EXCEPT WHERE SHOWN OTHERWISE ON THE PLANS. THE MINIMUM SIZE FOR FIELD POWER AND CONTROL WIRING SHALL BE 12AWG. INSULATION SHALL HAVE A 600V MINIMUM RATING, AND BE RATED FOR 90 DEG CELSIUS.

NEUTRAL CONDUCTORS SHALL NOT BE SHARED BETWEEN MULTIPLE BRANCH CIRCUITS, EXCEPT FOR DESIGNATED MULTIPLE LIGHTING AND RECEPTACLE CIRCUITS WHERE CLEARLY SHOWN ON THE PLANS.

CONDUCTOR FILL IN RACEWAYS SHALL NOT EXCEED 40%. MINIMUM CONDUIT SIZE SHALL BE 3/4 INCH.

WIRING IN ENCLOSURES, CABINETS, BOXES, ETC. SHALL BE NEATLY ROUTED AND BUNDLED WITH PVC TIES OR PLACED IN NON-METALIC WIRING TROUGHS.

SPARE AND UN-TERMINATED CONDUCTORS SHALL BE CAPPED, OR CONNECTED TO SPARE TERMINAL BLOCKS WHERE AVAILABLE, AND CLEARLY IDENTIFIED. ONE FULL TURN OF SLACK FOR ALL SPARE CONDUCTORS SHALL BE PROVIDED IN ALL ENCLOSURES, CABINETS, BOXES, ETC.

RACEWAYS CROSSING EXPANSION JOINTS, OR OTHERWISE SUBJECT TO MOVEMENT, SHALL BE PROVIDED WITH EXPANSION AND/OR DEFLECTION FITTINGS OR OTHER APPROVED MEANS TO COMPENSATE FOR SUCH MOVEMENT. EACH SUCH EXPANSION AND/OR DEFLECTION MEANS SHALL BE PROVIDED WITH AN EXTERNAL COPPER BONDING JUMPER, SIZED 6 AWG MINIMUM.

CONDUCTOR SPLICES SHALL BE MADE ONLY IN JUNCTION BOXES, OUTLET OR DEVICE BOXES, TERMINAL CABINETS, AND EQUIPMENT ENCLOSURES. SPLICES SHALL BE MADE ON TERMINAL BLOCKS, EXCEPT FOR SPLICES AT LUMINAIRES AND WIRING DEVICES WHICH SHALL UTILIZE INSULATED SET-SCREW TYPE, OR SIMILAR APPROVED CONNECTIONS. TWIST-ON (WIRENUT) TYPE CONNECTIONS SHALL NOT BE USED, EXCEPT FOR LIGHTING OR OUTLET CIRCUITS OF 120 VOLTS, 20 AMPS OR LESS. TERMINAL BLOCKS SHALL NOT HAVE MORE THAN TWO CONDUCTORS PER TERMINAL.

LAYOUT OF TERMINAL BLOCKS IN JUNCTION BOXES AND TERMINAL CABINETS SHALL COMPLY WITH THE REQUIREMENTS FOR WIRE BENDING SPACE GIVEN IN NEC 312.6, EXCEPT THAT THE MINIMUM SPACE PERMITTED SHALL BE 2 INCHES. PROPOSED LAYOUTS, INCLUDING ANTICIPATED LOCATIONS AND SIZES OF KNOCKOUTS, SHALL BE SUBMITTED FOR APPROVAL PRIOR TO FABRICATION.

TERMINAL BLOCKS, POWER DISTRIBUTION BLOCKS, AND CRIMP TYPE CONNECTORS SHALL BE RATED FOR 90 DEG CELSIUS.

A CONDUIT BODY OR BOX SHALL BE PROVIDED ON AT LEAST ONE SIDE OF ALL FLEXIBLE CONDUCTORS.

ALL RACEWAYS SHALL BE ARRANGED TO DRAIN. CONDUIT DRAINS SHALL BE INSTALLED IN A CONDUIT BODY AT THE LOW POINT OF ALL RUNS.

UNLESS SPECIFICALLY INDICATED OTHERWISE, CONDUIT AND CABLE ENTRANCES IN DAMP AND WET LOCATIONS SHALL BE MADE ONLY AT THE BOTTOM OF CABINETS AND/OR ENCLOSURES.

CONDUCTORS WITH GREEN COLORED INSULATION MAY BE USED ONLY FOR GROUNDING CONDUCTORS. RE-IDENTIFICATION OF CONDUCTORS, SUCH AS WITH GREEN COLORED TAPE, IS NOT PERMITTED.

MISCELLANEOUS MATERIALS AND METHODS

ALL BOLTS, NUTS, WASHERS, CONCRETE ANCHORS, AND SIMILAR HARDWARE SHALL BE TYPE 316 STAINLESS STEEL. ALL CONCRETE ANCHORS SHALL BE EPOXY ADHESIVE TYPE.

ALL BOLTED AND SIMILAR CONNECTIONS SHALL UTILIZE LOCK WASHERS. CONNECTIONS WHICH DO NOT PERMIT THE USE OF LOCK WASHERS SHALL UTILIZE AN APPROVED MEDIUM STRENGTH THREAD-LOCKING ADHESIVE.

SUPPORTS FOR ELECTRICAL EQUIPMENT SHALL BE FABRICATED FROM TYPE 316 STAINLESS STEEL OR TYPE A36 STEEL (HOT DIPPED GALVANIZED AFTER FABRICATION).

EQUIPMENT ENCLOSURES, CABINETS, BOXES, AND SIMILAR ITEMS SHALL BE INSTALLED PLUMB AND SECURELY FASTENED IN PLACE.

IDENTIFICATION

THE CONTRACTOR SHALL BE RESPONSIBLE FOR DEVELOPING A COMPREHENSIVE WIRE NUMBERING SYSTEM CONSISTANT WITH EXISTING WIRING AND SHALL LABEL ALL WIRES, CABLES, AND TERMINAL BLOCKS. IDENTIFICATION NUMBERS SHALL BE COORDINATED FOR CONSISTENCY AND ACCURACY WITH NUMBERS SHOWN ON THE CONTRACTOR'S WIRING DIAGRAMS AND SHOP DRAWINGS, FIELD WIRING DIAGRAMS, AND ANY OTHER DIAGRAMS SHOWING THE SAME ITEM.

ALL CONDUCTORS, INCLUDING SPARES, SHALL BE UNIQUELY IDENTIFIED AND CLEARLY LABELED WITH MACHINE PRINTED, WEATHERPROOF, NON-SHRINK SLEEVE TYPE LABELS. EACH CONDUCTOR SHALL BE ASSIGNED ONLY ONE IDENTIFICATION NUMBER THROUGHOUT ITS ENTIRE ROUTING FROM ORIGIN TO DESTINATION POINT(S).

ALL TERMINAL BLOCKS SHALL BE CLEARLY LABELED AT EACH TERMINAL POSITION WITH ENGRAVED PLASTIC WEATHERPROOF LABELS (WHITE TEXT ON BLACK BACKGROUND) ATTACHED WITH STAINLESS STEEL HARDWARE.

ALL ELECTRICAL EQUIPMENT ENCLOSURES, PULL BOXES, JUNCTION BOXES, LOAD PANELS, AND SIMILAR ITEMS SHALL BE CLEARLY LABELED WITH ENGRAVED PLASTIC WEATHERPROOF LABELS (WHITE TEXT ON BLACK BACKGROUND) ATTACHED WITH STAINLESS STEEL HARDWARE.

GROUNDING AND BONDING

ALL CIRCUITS SHALL INCLUDE AN EQUIPMENT GROUNDING CONDUCTOR. EQUIPMENT GROUNDING CONDUCTORS SHALL BE SIZED EQUAL TO THE CIRCUIT CONDUCTORS, EXCEPT WHERE SHOWN OTHERWISE IN THE PLANS OR PERMITTED OTHERWISE BY THE NEC.

ALL GROUNDING TYPE HUBS AND CONNECTORS IN A BOX OR ENCLOSURE SHALL BE BONDED TOGETHER AND TO THE BOX OR ENCLOSURE WITH A STRANDED COPPER BONDING JUMPER SIZED EQUAL TO THE LARGEST EQUIPMENT GROUNDING CONDUCTOR IN THE BOX OR ENCLOSURE.

ALL GROUNDING CONDUCTORS WITHIN AN EQUIPMENT ENCLOSURE OR TERMINAL CABINET SHALL BE TERMINATED ON A COMMON UNINSULATED GROUNDING BAR.

REMOVALS:

PERFORM ALL REMOVALS IN SUCH A MANNER AS TO AVOID DAMAGE TO EXISTING EQUIPMENT AND/OR CONDUCTORS WHICH ARE TO REMAIN.

THE CONTRACTOR SHALL GIVE THE DEPARTMENT THE OPTION OF SALVAGING ANY ELECTRICAL EQUIPMENT WHICH IS TO BE REMOVED.

THE CONTRACTOR SHALL DELIVER ALL EQUIPMENT WHICH IS TO BE SALVAGED TO A LOCATION DESIGNATED BY THE DEPARTMENT. ALL EQUIPMENT WHICH IS TO BE SALVAGED SHALL BE HANDLED WITH CARE AT ALL TIMES TO AVOID DAMAGE.

ALL EQUIPMENT WHICH IS TO BE REMOVED AND IS NOT TO BE SALVAGED SHALL BECOME THE PROPERTY OF, AND BE REMOVED FROM THE PROJECT SITE BY THE CONTRACTOR.

THE CONTRACTOR SHALL BEAR FULL RESPONSIBILITY FOR THE PROPER DISPOSAL OF REMOVED EQUIPMENT AND/OR MATERIALS IN ACCORDANCE WITH ALL APPLICABLE REGULATIONS.

PROJECT NO. 15B.13.28
NEW HANOVER COUNTY

STATION: _____

SHEET 3 OF 16

STATE OF NORTH CAROLINA
 DEPARTMENT OF TRANSPORTATION
 RALEIGH

CAPE FEAR MEMORIAL
 LIFT BRIDGE
 ELECTRICAL NOTES - 1

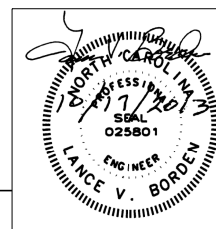











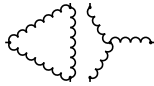

DRAWN BY : RLR DATE : 10/17/2013
 CHECKED BY : JGS DATE : 10/17/2013

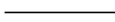
DWG NUMBER	TOTAL DWGS
E2	16

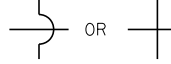
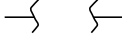
REVISIONS						SHEET NO.
NO.	BY:	DATE:	NO.	BY:	DATE:	3
1			3			TOTAL SHEETS
2			4			16



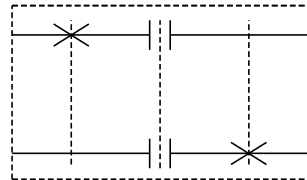

GENERAL ELECTRICAL POWER AND CONTROL CIRCUIT SCHEMATIC SYMBOLS

-  DISCONNECT SWITCH
-  CIRCUIT BREAKER (CB)
-  FUSE
-  THREE PHASE, DELTA-WYE TRANSFORMER
-  SINGLE PHASE TRANSFORMER
-  RESISTOR
-  TERMINAL BLOCK OR EQUIPMENT TERMINAL
-  WIRING
-  WIRING CONNECTION
-  WIRING NOT CONNECTED
-  WIRING CONNECTION
- TO OR FROM AS INDICATED
-  GROUND OR BONDING CONNECTION
-  BASIC (RELAY OR CONTACTOR) CONTACT
- NORMALLY OPEN OR NORMALLY CLOSED AS INDICATED
-  INTERPOSING RELAY (IR)
-  INDICATOR LIGHT (IL)
- COLOR AS INDICATED (A = AMBER, R = RED, G = GREEN, BL = BLUE, Y = YELLOW, W = WHITE)



SELECTOR SWITCH (SS) WITH PUSHBUTTON TYPE CONTACTS
- TEXT ADJACENT TO CONTACT INDICATES OPERATING SEQUENCE (O = OPEN, X = CLOSED)

PLC SYSTEM SYMBOLS

-  PLC DISCRETE OUTPUT (DO)
-  PLC DISCRETE INPUT (DI)
-  PLC INTERNAL (LOGICAL) COIL
-  PLC INTERNAL (LOGICAL) CONTACT
- NORMALLY OPEN OR NORMALLY CLOSED AS INDICATED

PROJECT NO. 15B.13.28
NEW HANOVER COUNTY
 STATION: _____

SHEET 4 OF 16

STATE OF NORTH CAROLINA
 DEPARTMENT OF TRANSPORTATION
 RALEIGH
 CAPE FEAR MEMORIAL
 LIFT BRIDGE
 ELECTRICAL NOTES - 2

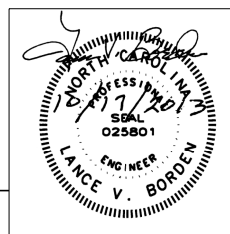

DRAWN BY : RLR DATE : 10/17/2013
 CHECKED BY : JGS DATE : 10/17/2013

10/18/2013 10:24:19 AM
 P:\2986.11\CADD\Electrical\4-E3-ELECTRICAL NOTES - 2.dgn

DWG NUMBER	TOTAL DWGS
E3	16

REVISIONS						SHEET NO.
NO.	BY:	DATE:	NO.	BY:	DATE:	4
1			3			TOTAL SHEETS
2			4			16

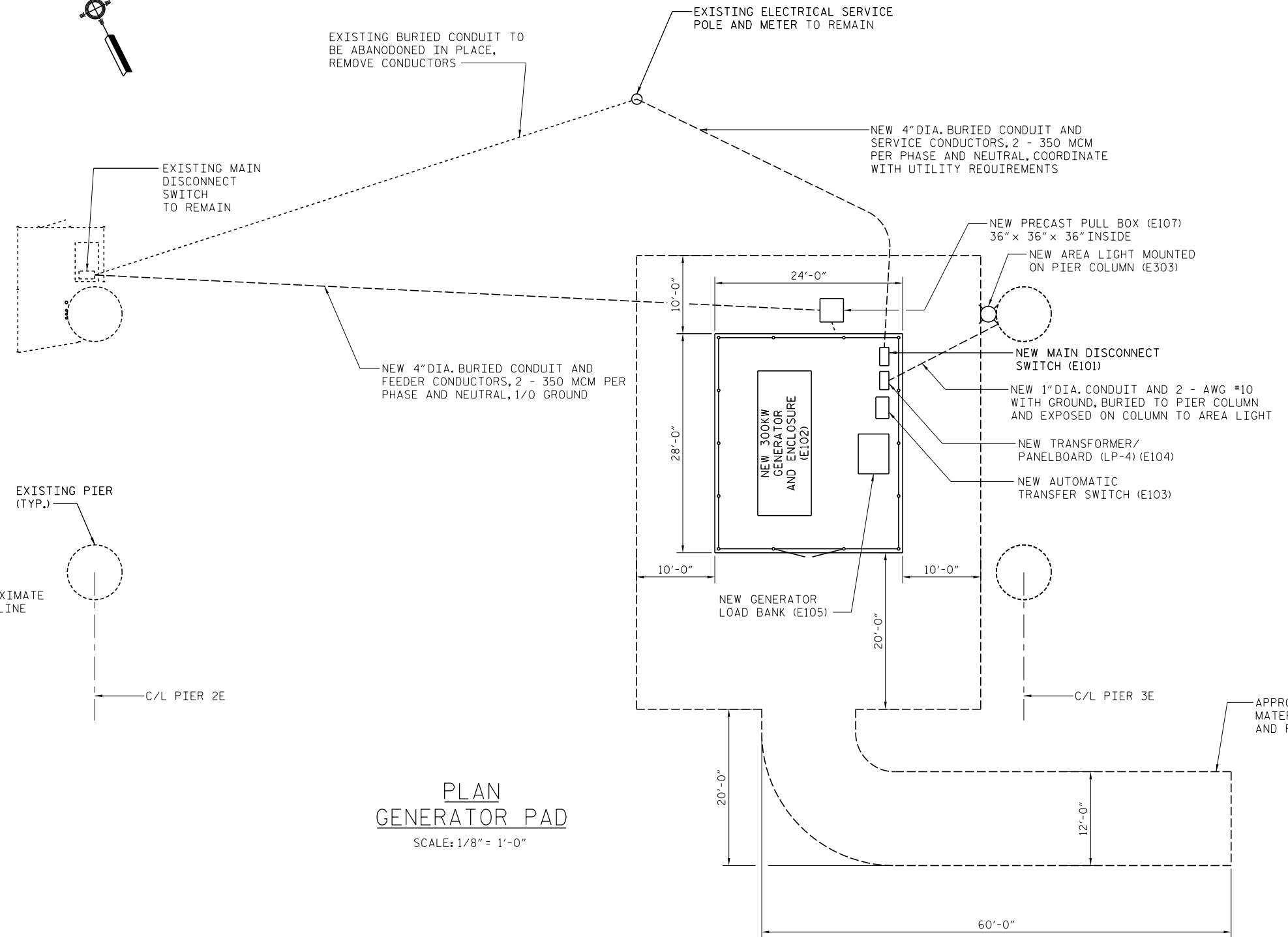
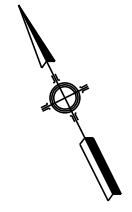

**PLAN
GENERATOR PAD**
SCALE: 1/8" = 1'-0"

PROJECT NO. 15B.13.28
NEW HANOVER COUNTY
 STATION: _____

SHEET 5 OF 16

STATE OF NORTH CAROLINA
 DEPARTMENT OF TRANSPORTATION
 RALEIGH
 CAPE FEAR MEMORIAL
 LIFT BRIDGE
 GENERATOR PAD
 DETAILS - 1

REVISIONS						SHEET NO.
NO.	BY:	DATE:	NO.	BY:	DATE:	TOTAL SHEETS
1			3			5
2			4			16

DRAWN BY : RLR DATE : 10/17/2013
 CHECKED BY : JGS DATE : 10/17/2013

10/18/2013 10:25:05 AM
 P:\2986.11\CADD\Electrical\5-E4-GENERATOR PAD DETAILS - 1.dgn

MODJESKI and MASTERS
 Experience great bridges.
 Mechanicsburg, PA NC License No. C-2979

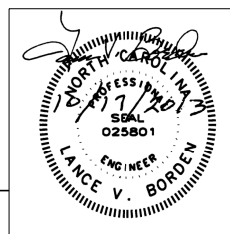

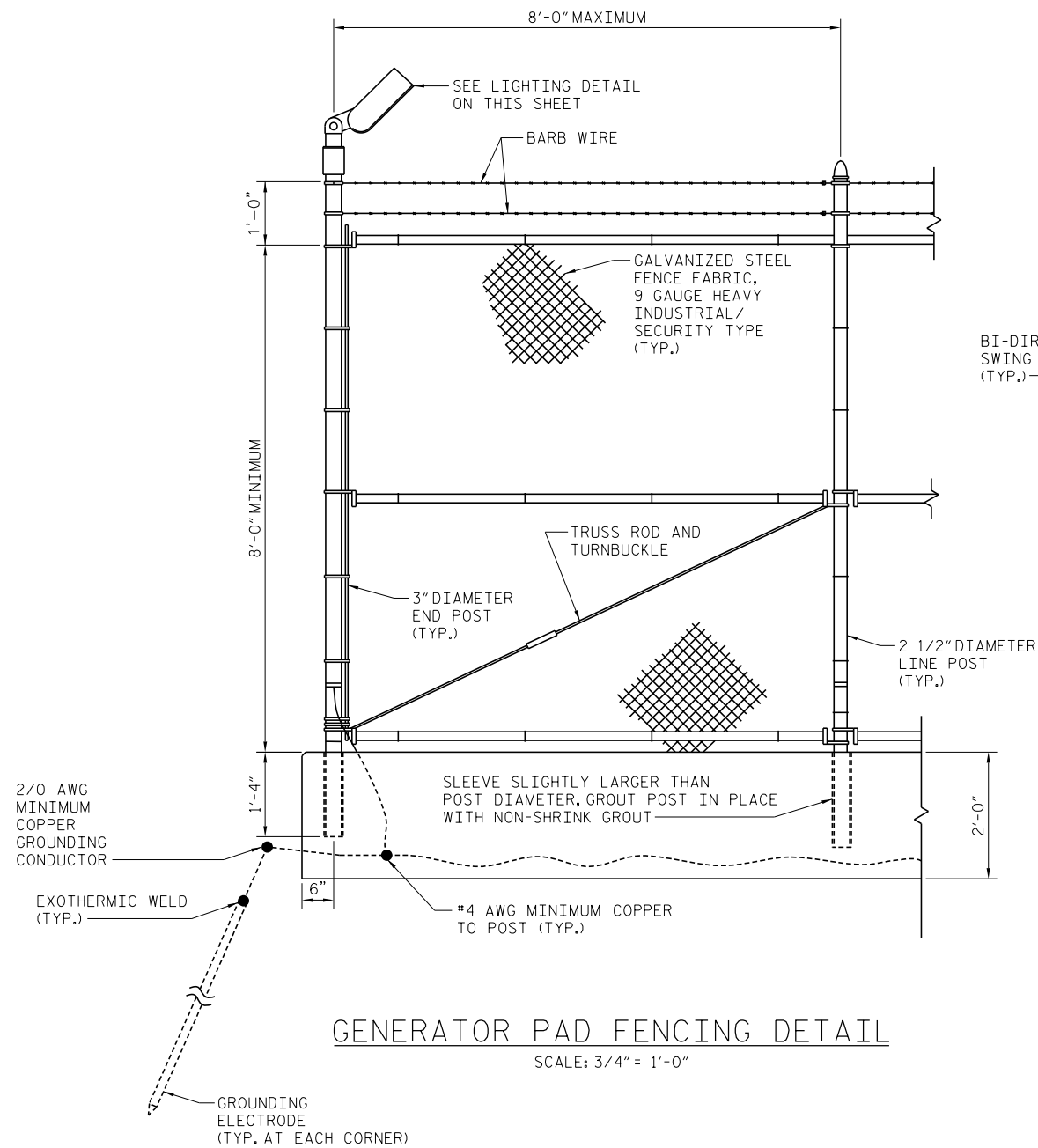

GENERATOR PAD FENCING DETAIL

SCALE: 3/4" = 1'-0"

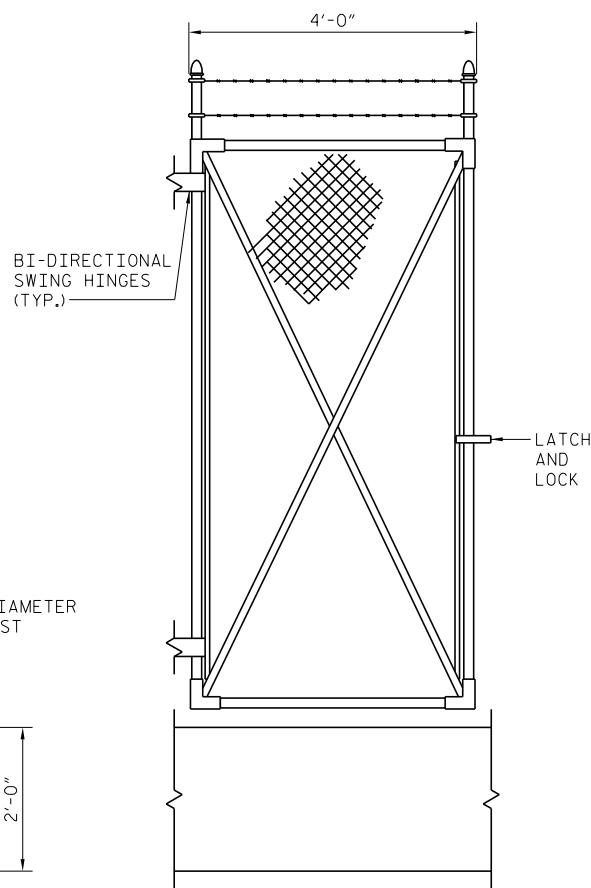

SWING GATE DETAIL

SCALE: 3/4" = 1'-0"

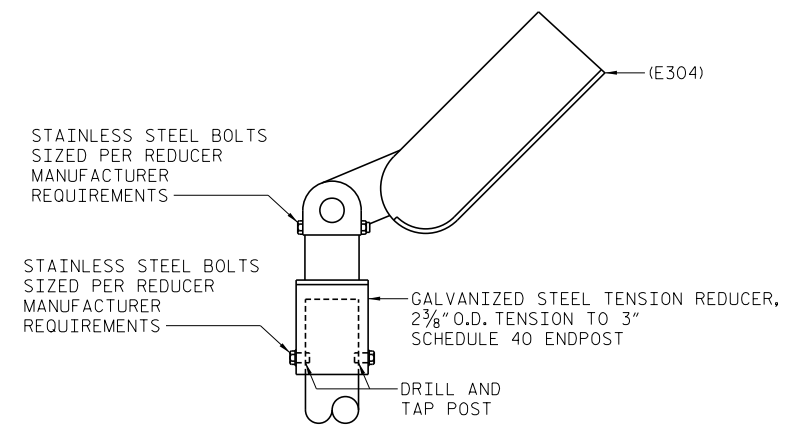

LIGHTING DETAIL TYP. FOR (4) LOCATIONS

SCALE: NONE

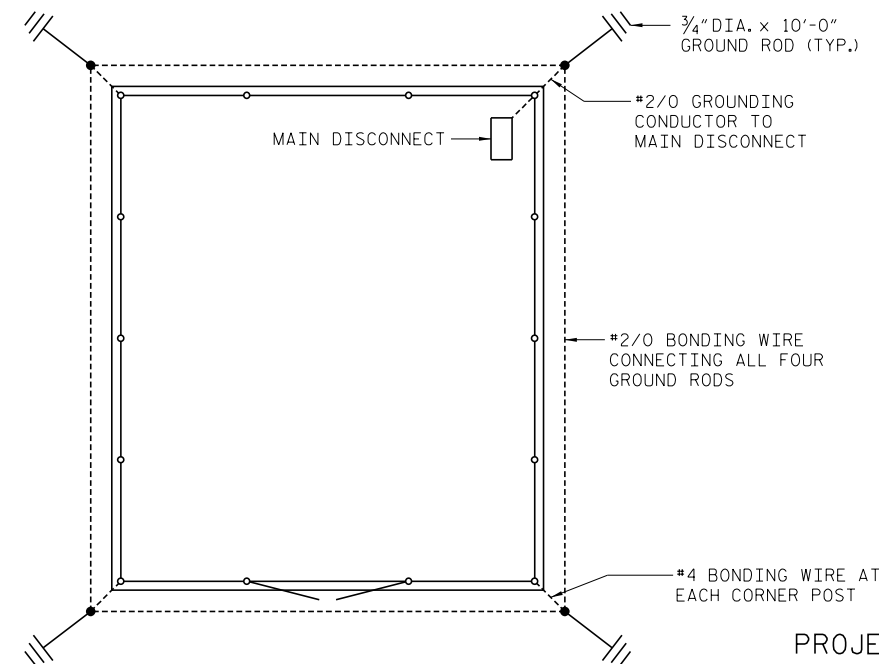

GROUNDING DETAIL

SCALE: NONE

NOTES:

1. CHAIN LINK FABRIC, POSTS, RAILS, GATES, AND OTHER ASSOCIATED HARDWARE SHALL BE GALVANIZED STEEL. A MOSITURE-EXCLUDING CAP IS REQUIRED FOR ALL POSTS.
2. POSTS SHALL BE HIGH STRENGTH SCHEDULE 40 PIPE, TOP RAIL BRACE RAIL, AND BOTTOM RAIL SHALL BE 1 5/8" DIAMETER, TRUSS ROD ADJUSTING UNITS SHALL BE 3/8" DIAMETER MINIMUM.
3. THE SWING GATE SHALL HAVE LOCKABLE TYPE HARDWARE WITH CORROSION RESISTANT LOCK. LOCK TYPE AND KEYING SHALL BE AS SPECIFIED BY THE DEPARTMENT.
4. BONDING CONNECTIONS TO POSTS, FABRIC, AND BARBED WIRE SHALL BE MADE WITH UL LISTED GROUND CLAMPS. COMPRESSION TYPE CONNECTORS SHALL BE SUITABLE FOR USE WITH COPPER.
5. PROVIDE AND INSTALL FOUR GROUNDING ELECTRODES, ONE AT EACH CORNER OF THE GENERATOR PAD, GROUNDING ELECTRODES SHALL BE DRIVEN TO A DEPTH OF AT LEAST 12 INCHES BELOW FINISHED GRADE. INSTALL A GROUNDING RING AROUND THE PERIMETER OF THE PAD AT A SIMILAR DEPTH BELOW GRADE.
6. GROUNDING CONDUCTORS FOR FENCE GROUNDING SHALL BE AWG SOLID COPPER WITH TIN PLATING, GATES SHALL BE BONDED WITH AWG 2 FLEXIBLE STRANDED COPPER CONDUCTORS.
7. PROVIDE GROUNDING CONNECTIONS TO THE GROUNDING RING FOR THE GENERATOR AND LOAD PANEL AS SHOWN IN THE PLANS.
8. FENCING SHALL COMPLY WITH NCDOT SECTION 866.

PROJECT NO. 15B.13.28
NEW HANOVER COUNTY

STATION: _____

SHEET 6 OF 16

STATE OF NORTH CAROLINA
 DEPARTMENT OF TRANSPORTATION
 RALEIGH

CAPE FEAR MEMORIAL
 LIFT BRIDGE
 GENERATOR PAD
 DETAILS - 2



Mechanicsburg, PA NC License No. C-2979

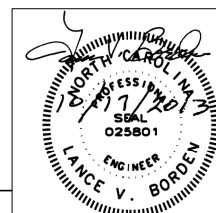

DRAWN BY : RLR DATE : 10/17/2013
 CHECKED BY : JGS DATE : 10/17/2013

10/18/2013 10:25:43 AM
 P:\2986.11\CADD\Electrical\6-E5-GENERATOR PAD DETAILS - 2.dgn

DWG NUMBER	TOTAL DWGS
E5	16

REVISIONS						SHEET NO.
NO.	BY:	DATE:	NO.	BY:	DATE:	TOTAL SHEETS
1			3			6
2			4			16

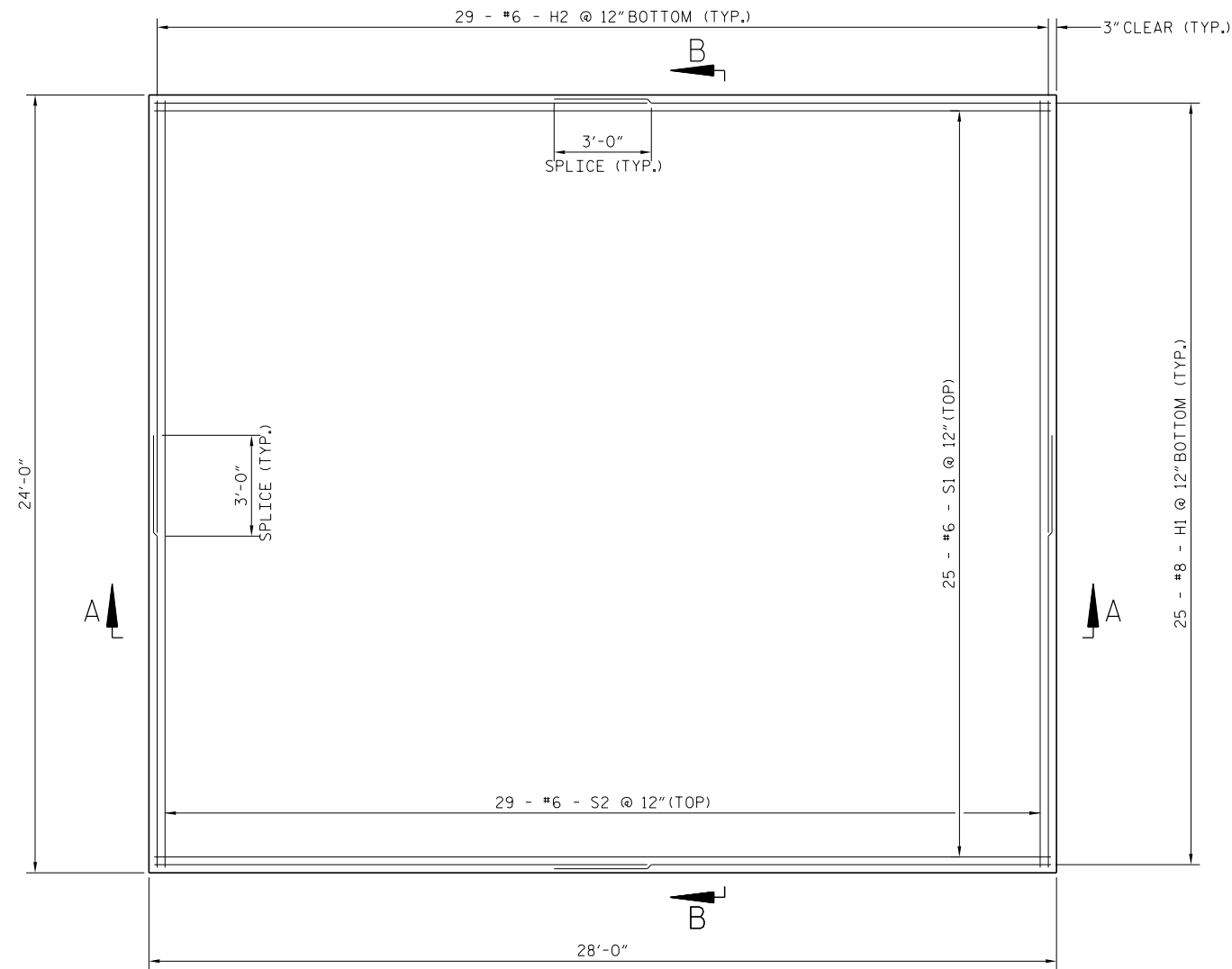

PLAN
SCALE: 3/8" = 1'-0"

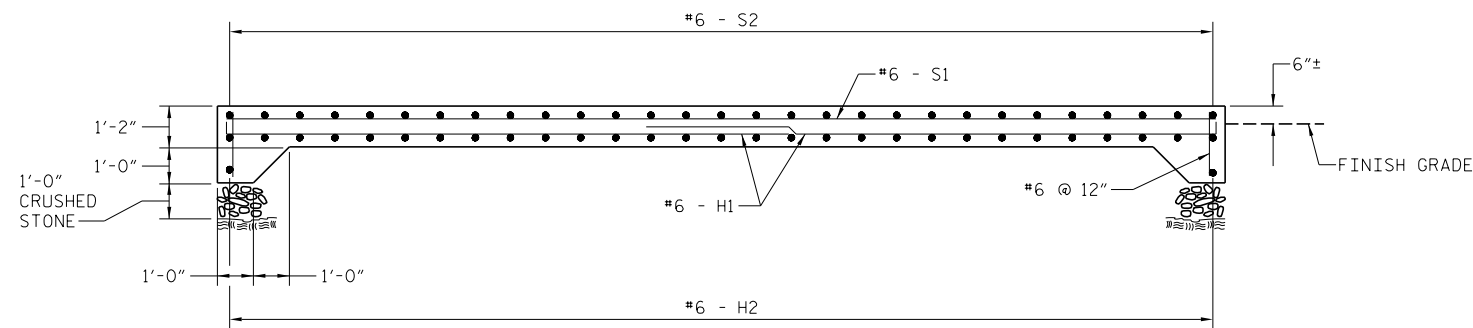

SECTION A-A
SCALE: 3/8" = 1'-0"

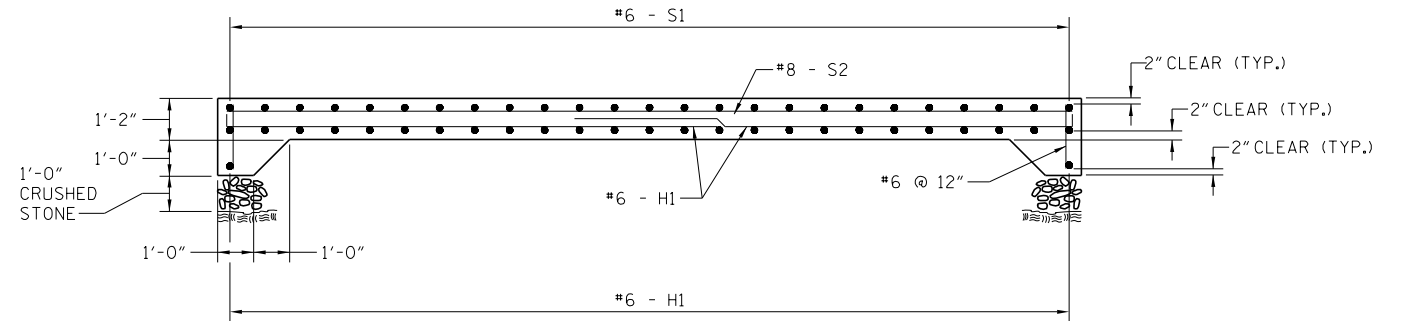

SECTION B-B
SCALE: 3/8" = 1'-0"

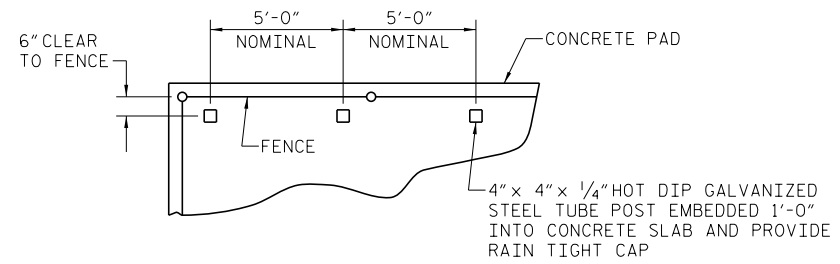

PLAN
EQUIPMENT FRAME POSTS DETAIL
SCALE: NONE

NOTES:

1. CONSTRUCT GENERATOR PAD IN ACCORDANCE WITH NCDOT STANDARDS SECTION 420.
2. USE CLASS A CONCRETE. REINFORCING STEEL TO BE UNCOATED.

PROJECT NO. 15B.13.28
NEW HANOVER COUNTY

STATION: _____

SHEET 7 OF 16

STATE OF NORTH CAROLINA
DEPARTMENT OF TRANSPORTATION
RALEIGH

CAPE FEAR MEMORIAL
LIFT BRIDGE
GENERATOR PAD
DETAILS - 3

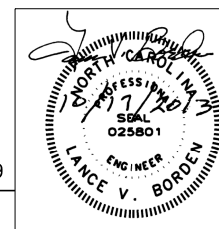

DRAWN BY : RLR DATE : 10/17/2013
CHECKED BY : JGS DATE : 10/17/2013

10/18/2013 10:26:13 AM
P:\2986.11\CADD\Electrical\7-E6-GENERATOR PAD DETAILS - 3.dgn

DWG NUMBER	TOTAL DWGS
E6	16

REVISIONS						SHEET NO.
NO.	BY:	DATE:	NO.	BY:	DATE:	7
1			3			TOTAL SHEETS
2			4			16

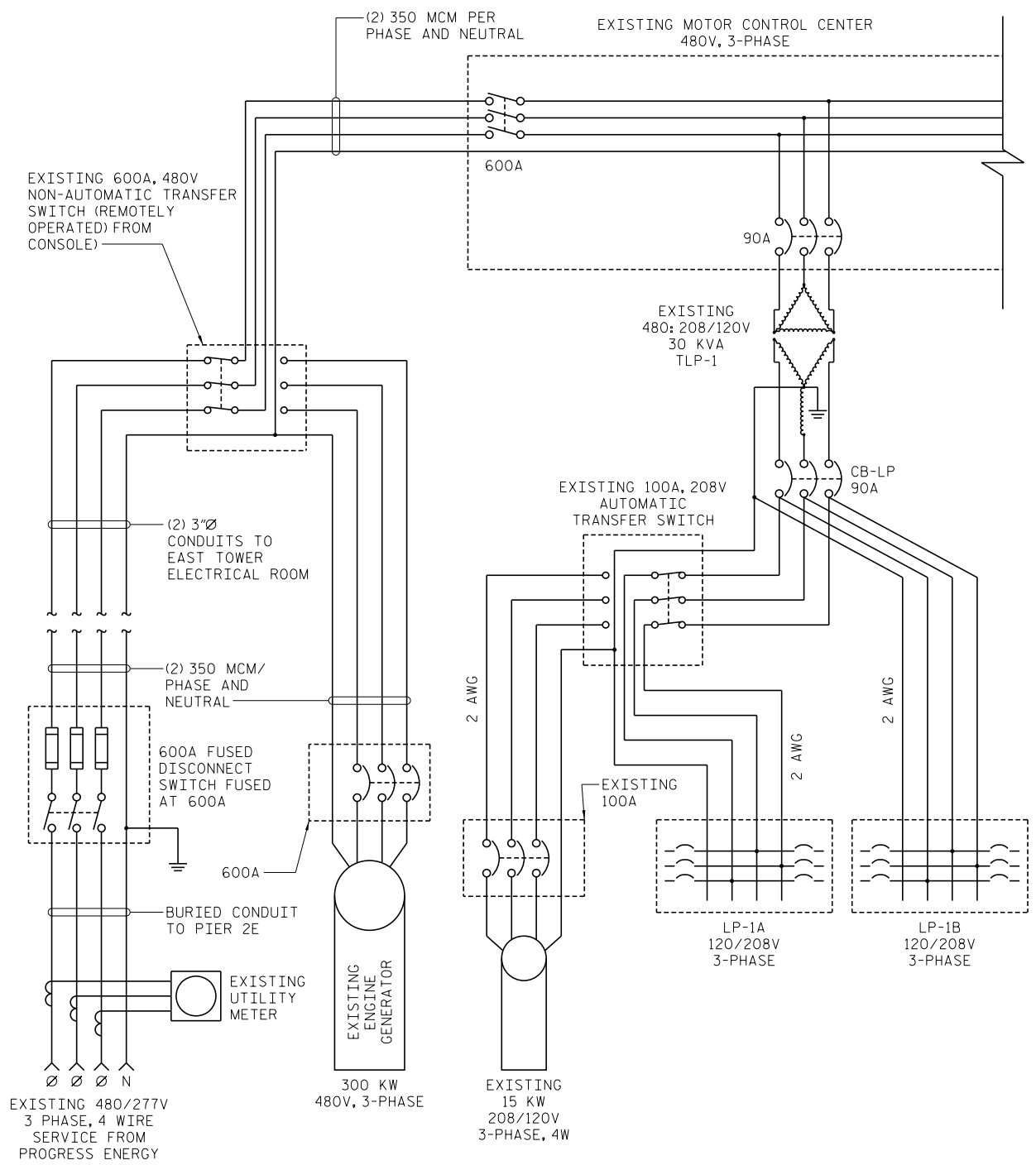

EXISTING THREE LINE DIAGRAM WITH EXISTING GENERATORS

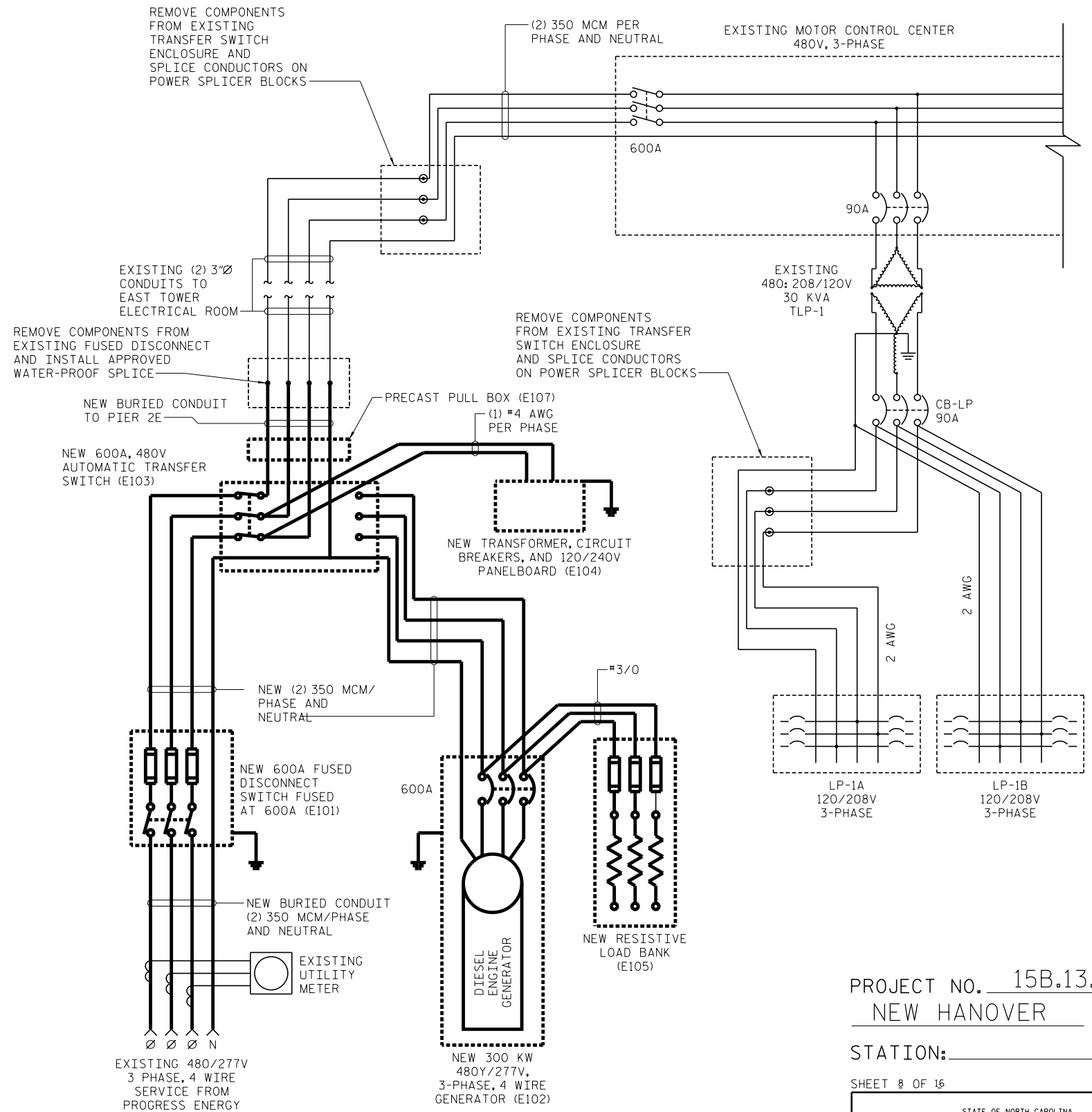

NEW THREE LINE DIAGRAM WITH NEW GENERATOR

- NOTES:**
1. ALL NEW COMPONENTS AND CONDUCTOR RATINGS SHALL COMPLY WITH THE NATIONAL ELECTRICAL CODE.
 2. THE LAYOUT IS DIAGRAMMATIC AND IS NOT INTENDED TO SHOW CONTROLS, WIRING AND EQUIPMENT IN THEIR EXACT PHYSICAL RELATIONSHIP.
 3. IN ADDITION TO CONDUCTORS SHOWN, ALL NEW CIRCUITS SHALL INCLUDE A GROUND CONDUCTOR SIZED IN ACCORDANCE WITH N.E.C. ARTICLE 250.

PROJECT NO. 15B.13.28
 NEW HANOVER COUNTY
 STATION: _____

SHEET 8 OF 16

STATE OF NORTH CAROLINA
 DEPARTMENT OF TRANSPORTATION
 RALEIGH

CAPE FEAR MEMORIAL
 LIFT BRIDGE
 THREE LINE DIAGRAM

REVISIONS						SHEET NO.	
NO.	BY:	DATE:	NO.	BY:	DATE:	8	
1			3			TOTAL SHEETS	
2			4			16	

DRAWN BY : RLR DATE : 10/17/2013
 CHECKED BY : JGS DATE : 10/17/2013

10/18/2013 10:26:42 AM
 P:\2986.11\CADD\Electrical\8-E7-THREE LINE DIAGRAM.dgn

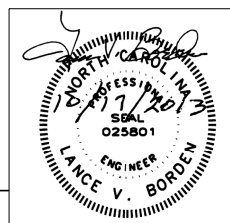

DWG NUMBER	TOTAL DWGS
E7	16

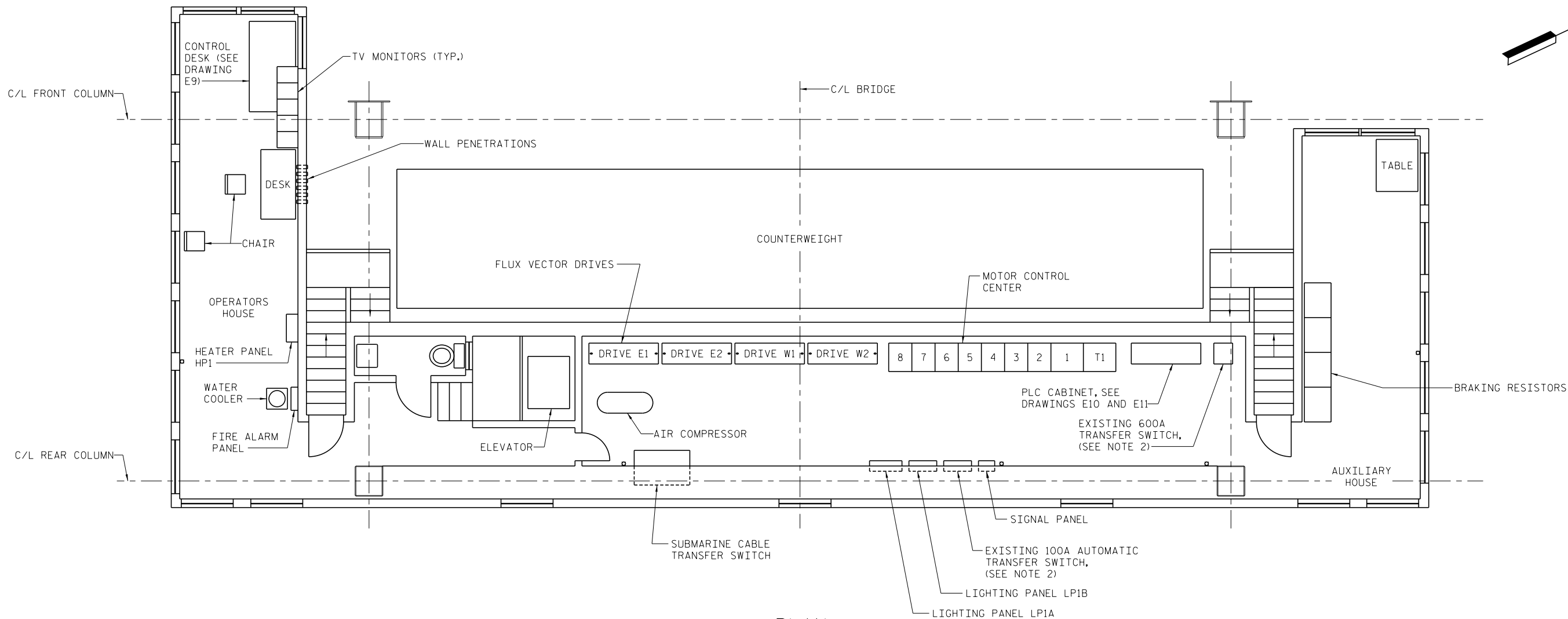
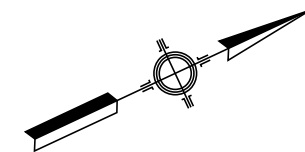

PLAN
CONTROL HOUSE - EQUIPMENT LAYOUT
 SCALE: 1/4" = 1'-0"

NOTES:

1. LOCATIONS SHOWN ARE APPROXIMATE.
2. REMOVE TRANSFER SWITCHES AND COMPONENTS FROM EXISTING 100A AND 600A TRANSFER SWITCH CABINETS. INSTALL NEW POWER BLOCKS IN CABINETS AND REUSE CABINETS AS POWER TERMINAL CABINETS.

PROJECT NO. 15B.13.28
NEW HANOVER COUNTY

STATION: _____

SHEET 9 OF 16

STATE OF NORTH CAROLINA
 DEPARTMENT OF TRANSPORTATION
 RALEIGH

CAPE FEAR MEMORIAL
 LIFT BRIDGE
 CONTROL HOUSE

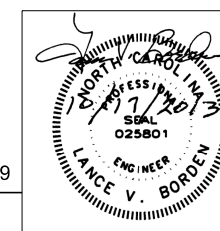

DRAWN BY : RLR DATE : 10/17/2013
 CHECKED BY : JGS DATE : 10/17/2013

10/18/2013 10:27:11 AM
 P:\2986.11\CADD\Electrical\9-E8-CONTROL HOUSE.dgn

DWG NUMBER E8 TOTAL DWGS 16

REVISIONS						SHEET NO.
NO.	BY:	DATE:	NO.	BY:	DATE:	9
1			3			TOTAL SHEETS
2			4			16

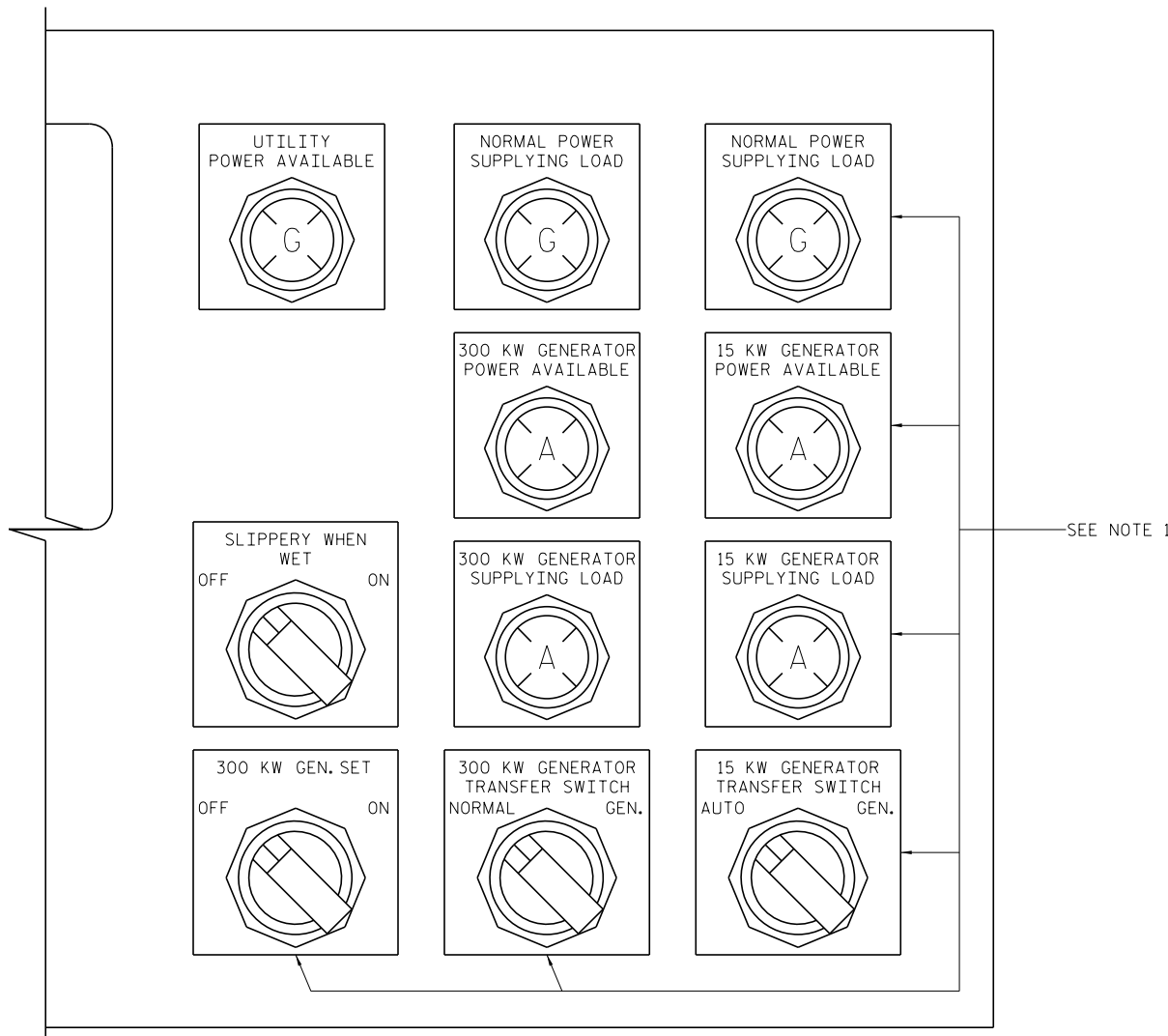

EXISTING BRIDGE CONTROL CONSOLE
EXISTING PUSHBUTTON LAYOUT

SCALE: 1" = 1"

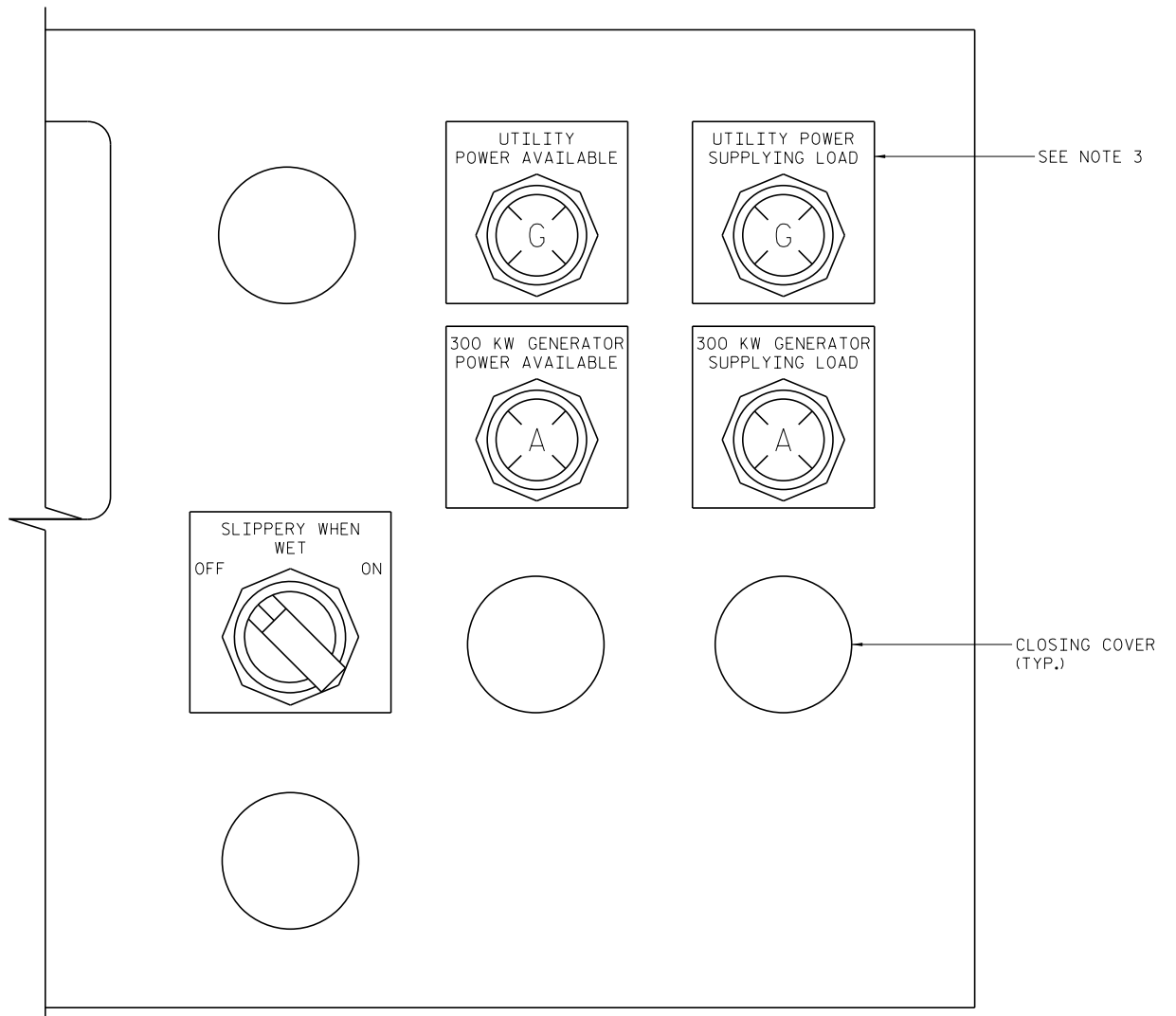

EXISTING BRIDGE CONTROL CONSOLE
NEW PUSHBUTTON LAYOUT

SCALE: 1" = 1"

NOTES:

1. REMOVE SWITCHES, LIGHTS AND ASSOCIATED WIRING. RELOCATE REMAINING INDICATOR LIGHTS TO LOCATIONS SHOWN. PROVIDE NEW WIRING OF SIMILAR STYLE WHERE REQUIRED.
2. PERFORM ALL WORK TO MAINTAIN OPERATION OF EQUIPMENT TO REMAIN. THE CONTRACTOR SHALL VERIFY PROPER OPERATION OF THE CONTROL CONSOLE AFTER THE WORK HAS BEEN PERFORMED.
3. PROVIDE NEW LABEL AS SHOWN. NEW LABEL SHALL MATCH STYLE OF CURRENTLY INSTALLED LABELS.
4. PROVIDE AND INSTALL MANUFACTURER'S STAINLESS STEEL PUSHBUTTON CLOSING COVERS FOR ALL UNUSED HOLES.
5. PROVIDE AND INSTALL GENERATOR REMOTE STATUS PANEL. WALL MOUNT STATUS PANEL IN THE VICINITY OF THE CONTROL CONSOLE AS DIRECTED BY THE ENGINEER.

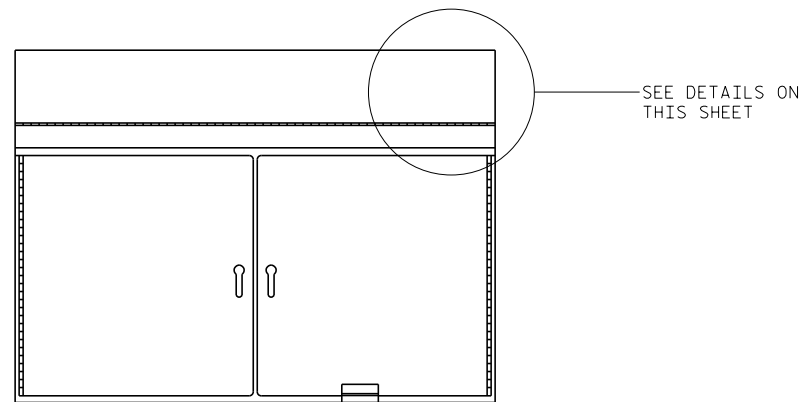

CONTROL CONSOLE

SCALE: 1" = 1'-0"

PROJECT NO. 15B.13.28
NEW HANOVER COUNTY

STATION: _____

SHEET 10 OF 16

STATE OF NORTH CAROLINA
DEPARTMENT OF TRANSPORTATION
RALEIGH

CAPE FEAR MEMORIAL
LIFT BRIDGE
CONTROL CONSOLE

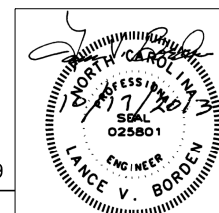

REVISIONS						SHEET NO.
NO.	BY:	DATE:	NO.	BY:	DATE:	10
1			3			TOTAL SHEETS
2			4			16

DRAWN BY : RLR DATE : 10/17/2013
CHECKED BY : JGS DATE : 10/17/2013

10/18/2013 10:27:47 AM
P:\2986.11\CADD\Electrical\10-E9-CONTROL CONSOLE.dgn

DWG NUMBER E9 TOTAL DWGS 16

+

+

HARDWIRED OUTPUTS
(EXISTING)

INTERNAL PLC LOGIC
(EXISTING)

HARDWIRED INPUTS
(EXISTING)

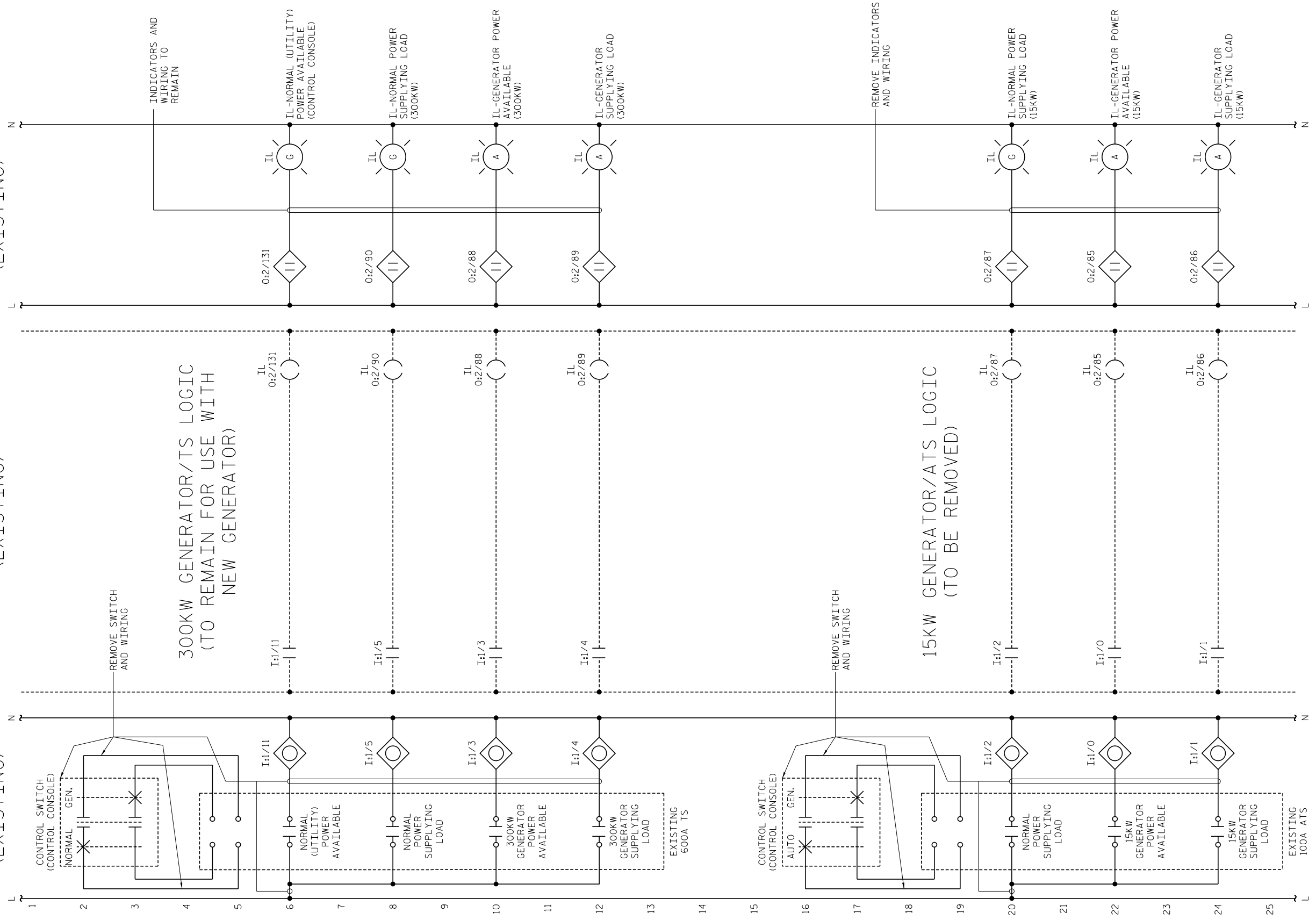

DRAWN BY : RLR DATE : 10/17/2013
 CHECKED BY : JGS DATE : 10/17/2013

10/18/2013 10:05:50 AM
 P:\2986.11\CADD\Electrical\11-E10-CONTROL CIRCUITS - EXISTING.dgn



Mechanicsburg, PA NC License No. C-2979

DWG NUMBER	TOTAL DWGS
E10	16

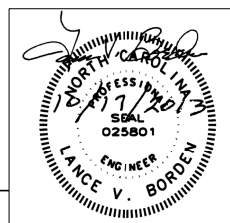

PROJECT NO. 15B.13.28
 NEW HANOVER COUNTY
 STATION: _____

SHEET 11 OF 16

STATE OF NORTH CAROLINA
 DEPARTMENT OF TRANSPORTATION
 RALEIGH

CAPE FEAR MEMORIAL
 LIFT BRIDGE
 CONTROL CIRCUITS -
 EXISTING

REVISIONS						SHEET NO.
NO.	BY:	DATE:	NO.	BY:	DATE:	11
1			3			TOTAL SHEETS
2			4			16

HARDWIRED INPUTS
(REUSE EXISTING FOR NEW EQUIPMENT)

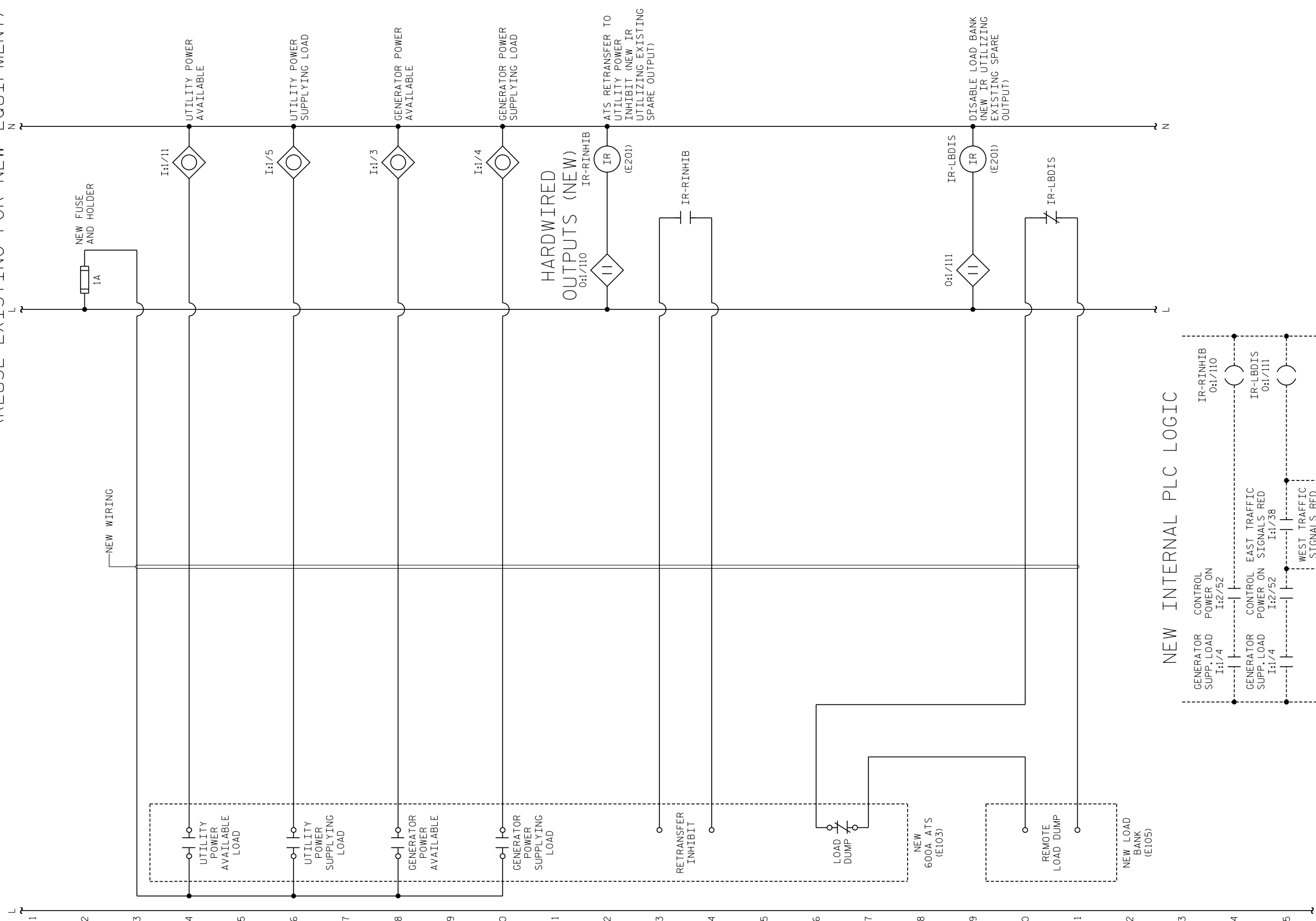

DRAWN BY : RLR DATE : 10/17/2013
 CHECKED BY : JGS DATE : 10/17/2013

10/18/2013 10:31:15 AM
 P:\2986.11\CADD\Electrical\12-E11-CONTROL CIRCUITS - NEW.dgn



Mechanicsburg, PA NC License No. C-2979

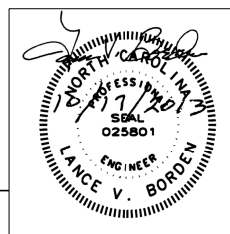

DWG NUMBER	TOTAL DWGS
E11	16

PROJECT NO. 15B.13.28
 NEW HANOVER COUNTY
 STATION: _____

SHEET 12 OF 16

STATE OF NORTH CAROLINA
 DEPARTMENT OF TRANSPORTATION
 RALEIGH
 CAPE FEAR MEMORIAL
 LIFT BRIDGE
 CONTROL CIRCUITS -
 NEW

REVISIONS						SHEET NO.
NO.	BY:	DATE:	NO.	BY:	DATE:	12
1			3			TOTAL SHEETS
2			4			16

GENERATOR PAD 120/240 PANELBOARD LP-4 (E104)					
VOLTAGE:	240/120 VOLTS	LOCATION:	GENERATOR PAD		
PHASE:	1	ENCLOSURE:	SURFACE, NEMA 3R		
WIRE:	3	TRANSFORMER:	15KVA		
BUS AMPERES:	100				
MAIN BREAKER:	80 AMPERE THERMAL-MAGNETIC BREAKER				
SHORT CIRCUIT:	65,000 SYMMETRICAL AMPERES				
DESCRIPTION	BREAKER POLES AMPS	A B		BREAKER AMPS POLES	DESCRIPTION
GENERATOR COOLANT HEATER	2 20	1	2	1 15	GEN. BATTERY CHARGER
RECEPTACLES	1 20	3	4	1 15	OUTDOOR POLE LIGHT
SPACE		5	6	1 15	AREA LIGHTING
SPACE		7	8	1 20	ALTERNATOR HEATER
RECEPTACLES	1 20	9	10	1 20	LOAD BANK CONTROL POWER
SPACE		11	12	1 20	LOAD BANK HEATER
SPACE		13	14		SPACE
SPACE		15	16		SPACE
SPACE		17	18		SPACE
SPACE		19	20		SPACE
SPACE		21	22		SPACE
SPACE		23	24		SPACE

GENERATOR PAD PANELBOARD SCHEDULE

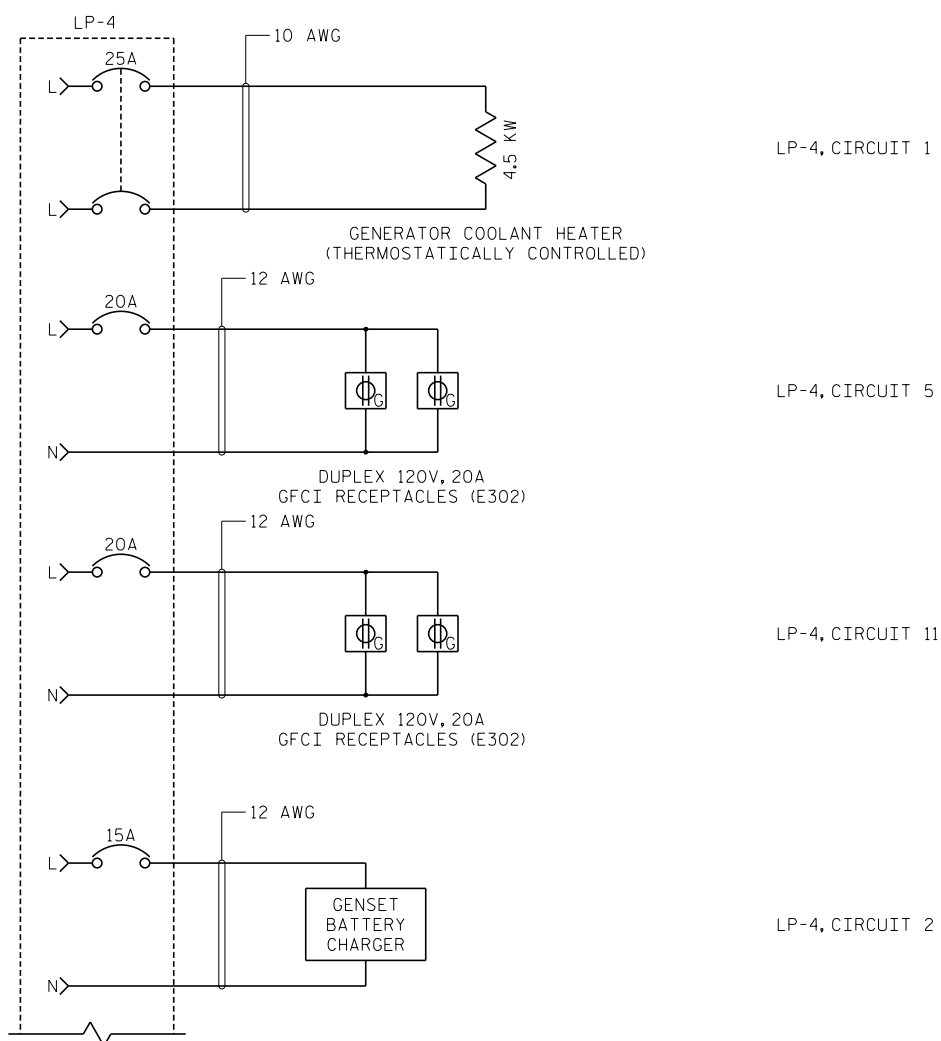

GENERATOR PAD PANELBOARD CIRCUITS

DRAWN BY : RLR DATE : 10/17/2013
 CHECKED BY : JGS DATE : 10/17/2013

10/18/2013 10:31:42 AM
 P:\2986.11\CADD\Electrical\13-E12-PANELBOARD SCHEDULE AND CIRCUITS.dgn

NOTES:

1. PROVIDE A NEAT TYPEWRITTEN OR COMPUTER GENERATED PRINTED CIRCUIT LABEL WITH CIRCUIT DESCRIPTIONS FOR PANELBOARD.
2. LAMINATE CIRCUIT LABEL IN CLEAR PLASTIC.
3. PROVIDE NAMEPLATE AT TOP CENTER OF PANELBOARD ATTACHED WITH STAINLESS STEEL OR BRONZE SCREWS AND SEALED WITH SILICONE RTV SEALANT. PLATES SHALL BE 1" x 3" LAMINATED PHENOLIC WITH BLACK BACKGROUND AND WHITE LETTERING.
4. ALL EQUIPMENT AND WIRING SHOWN IS NEW.

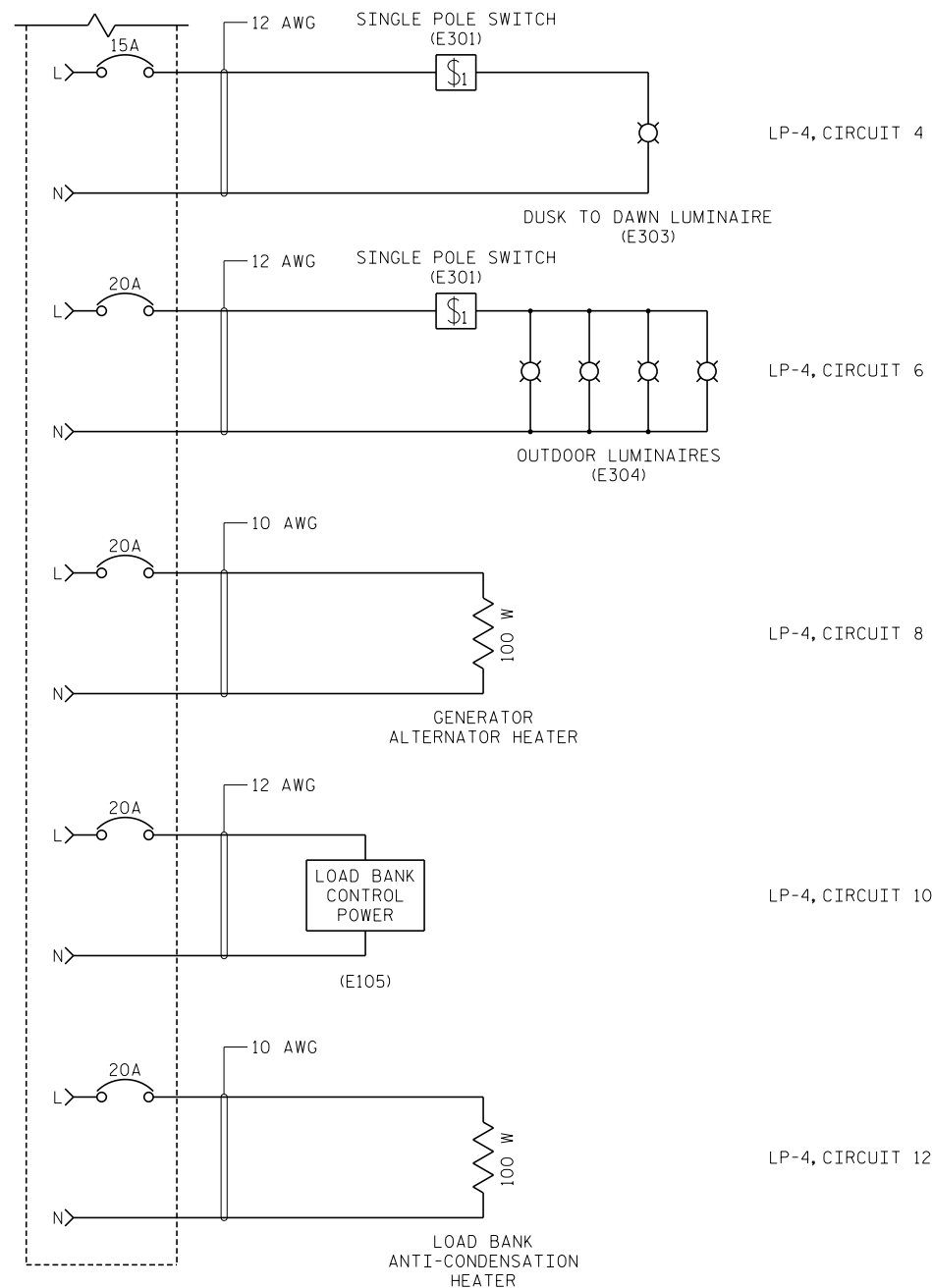

GENERATOR PAD PANELBOARD CIRCUITS (CONTINUED)

PROJECT NO. 15B.13.28
 NEW HANOVER COUNTY

STATION: _____

SHEET 13 OF 16

STATE OF NORTH CAROLINA
 DEPARTMENT OF TRANSPORTATION
 RALEIGH

CAPE FEAR MEMORIAL
 LIFT BRIDGE
 PANELBOARD SCHEDULE
 AND CIRCUITS



Mechanicsburg, PA NC License No. C-2979

DWG NUMBER	TOTAL DWGS
E12	16

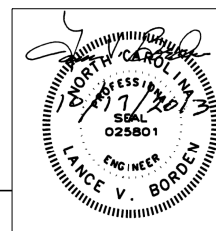

REVISIONS						SHEET NO.
NO.	BY:	DATE:	NO.	BY:	DATE:	13
1			3			TOTAL SHEETS
2			4			16

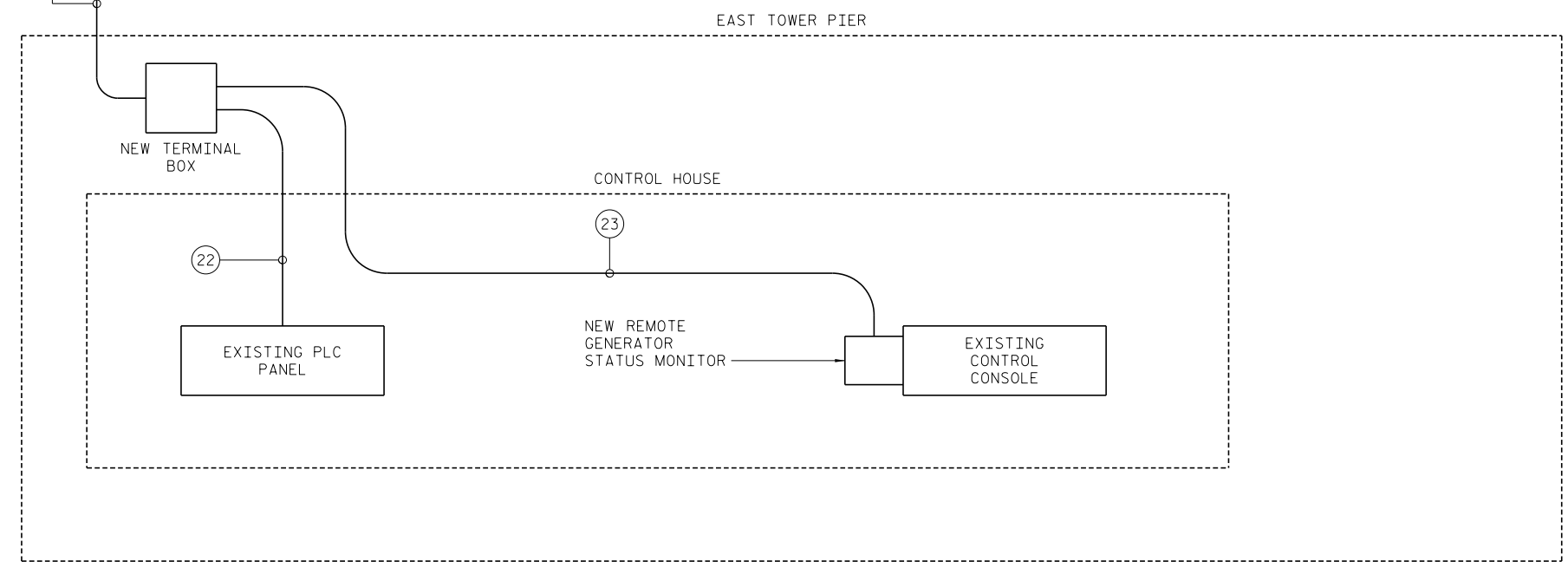
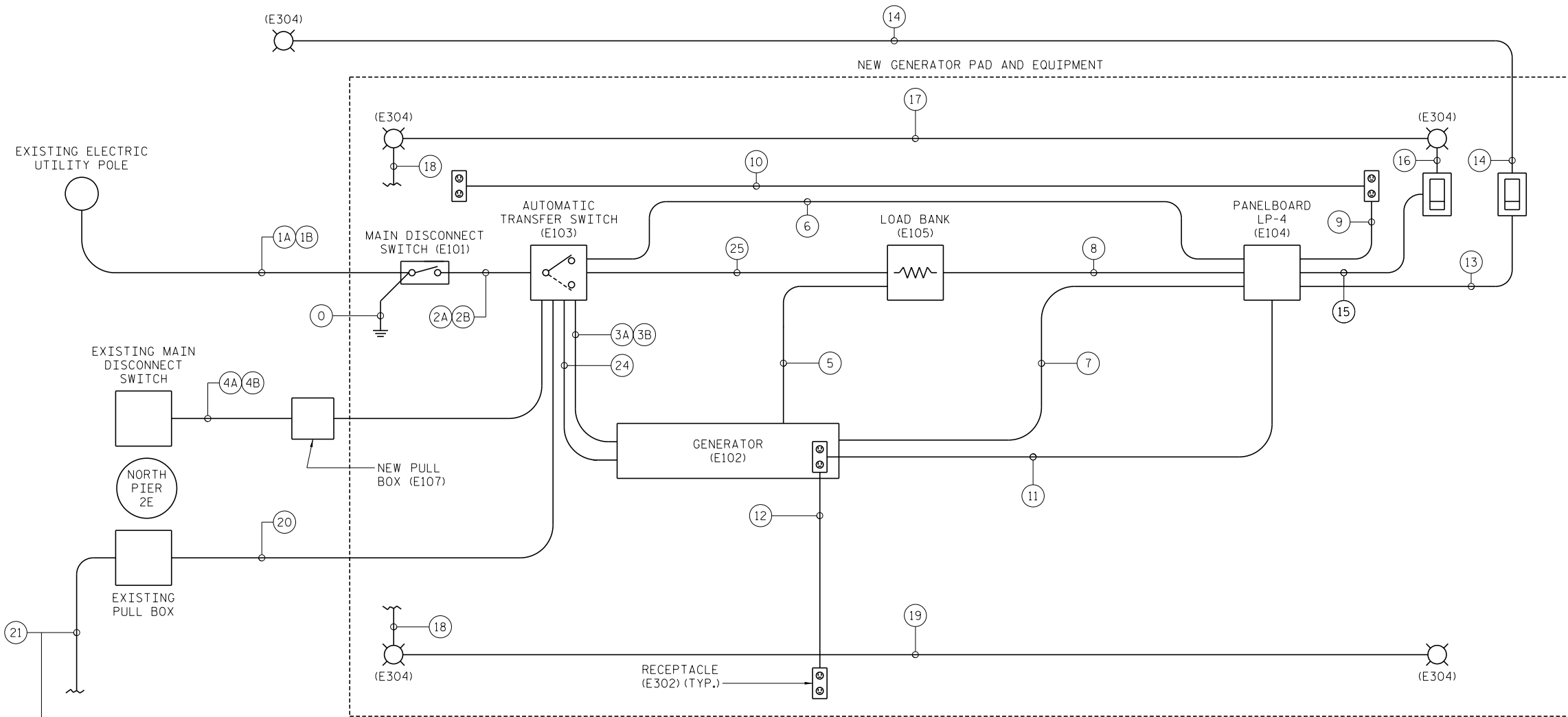

NOTES:

1. THIS LAYOUT IS DIAGRAMMATIC AND IS NOT INTENDED TO ILLUSTRATE THE EXACT PHYSICAL LOCATIONS OF EQUIPMENT OR RACWAY ROUTING.
2. THE CONTRACTOR SHALL BE RESPONSIBLE FOR DEVELOPING A COMPLETE WIRING AND CONDUIT TABULATION OF ALL CONDUCTORS. THE TABULATION SHALL BE SUBMITTED TO THE ENGINEER FOR APPROVAL.

PROJECT NO. 15B.13.28
NEW HANOVER COUNTY
 STATION: _____

SHEET 14 OF 16

STATE OF NORTH CAROLINA
 DEPARTMENT OF TRANSPORTATION
 RALEIGH
 CAPE FEAR MEMORIAL
 LIFT BRIDGE
 CONDUIT SCHEDULE - 1



Mechanicsburg, PA NC License No. C-2979

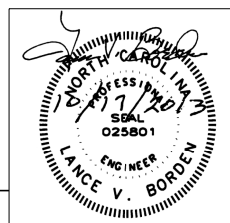

DRAWN BY : RLR DATE : 10/17/2013
 CHECKED BY : JGS DATE : 10/17/2013

DWG NUMBER	TOTAL DWGS
E13	16

REVISIONS						SHEET NO.
NO.	BY:	DATE:	NO.	BY:	DATE:	14
1			3			TOTAL SHEETS
2			4			16

CONDUIT SCHEDULE

CONDUIT NO.	SIZE	FROM	TO	WIRE	GND	NOTES
0	1"	MAIN SERVICE DISCONNECT SWITCH	GROUNDING ELECTRODE/GROUNDING RING		#2/0	GROUNDING ELECTRODE CONDUCTOR, PVC PLASTIC CONDUIT
1A	3"	INCOMING ELECTRICAL SERVICE	MAIN SERVICE DISCONNECT SWITCH	(4) 350 MCM	#1	BURIED CONDUIT, EMBEDDED IN GENERATOR PAD (COORDINATE WITH UTILITY)
1B	3"	INCOMING ELECTRICAL SERVICE	MAIN SERVICE DISCONNECT SWITCH	(4) 350 MCM	#1	BURIED CONDUIT, EMBEDDED IN GENERATOR PAD (COORDINATE WITH UTILITY)
2A	3"	MAIN SERVICE DISCONNECT SWITCH	AUTOMATIC TRANSFER SWITCH	(4) 350 MCM	#1	EMBEDDED IN GENERATOR PAD
2B	3"	MAIN SERVICE DISCONNECT SWITCH	AUTOMATIC TRANSFER SWITCH	(4) 350 MCM	#1	EMBEDDED IN GENERATOR PAD
3A	3"	AUTOMATIC TRANSFER SWITCH	GENERATOR	(4) 350 MCM	#1	EMBEDDED IN GENERATOR PAD
3B	3"	AUTOMATIC TRANSFER SWITCH	GENERATOR	(4) 350 MCM	#1	EMBEDDED IN GENERATOR PAD
4A	3"	AUTOMATIC TRANSFER SWITCH	EXISTING SERVICE DISCONNECT ENCLOSURE	(4) 350 MCM	#1	EMBEDDED IN GENERATOR PAD, BURIED CONDUIT
4B	3"	AUTOMATIC TRANSFER SWITCH	EXISTING SERVICE DISCONNECT ENCLOSURE	(4) 350 MCM	#1	EMBEDDED IN GENERATOR PAD, BURIED CONDUIT
5	3"	GENERATOR	LOAD BANK	(8) #3/0, (6) #12	#1	EMBEDDED IN GENERATOR PAD
6	1"	AUTOMATIC TRANSFER SWITCH	LP-4 TRANSFORMER/PANELBOARD	(2) #4	#6	EMBEDDED IN GENERATOR PAD
7	1"	LP-4 TRANSFORMER/PANELBOARD	GENERATOR	(4) #10, (2) #12	(2) #10, (1) #12	EMBEDDED IN GENERATOR PAD
8	3/4"	LP-4 TRANSFORMER/PANELBOARD	LOAD BANK	(2) #10, (2) #12	(1) #10, (1) #12	EMBEDDED IN GENERATOR PAD
9	3/4"	LP-4 TRANSFORMER/PANELBOARD	RECEPTACLE 1	(2) #12	(1) #12	EXPOSED CONDUIT/RACK
10	3/4"	RECEPTACLE 1	RECEPTACLE 2	(2) #12	(1) #12	EXPOSED CONDUIT/RACK
11	3/4"	LP-4 TRANSFORMER/PANELBOARD	RECEPTACLE 3	(2) #12	(1) #12	EMBEDDED IN GENERATOR PAD
12	3/4"	RECEPTACLE 3	RECEPTACLE 4	(2) #12	(1) #12	EMBEDDED IN GENERATOR PAD
13	3/4"	LP-4 TRANSFORMER/PANELBOARD	LIGHT SWITCH 1	(2) #12	(1) #12	EXPOSED CONDUIT/RACK
14	3/4"	LIGHT SWITCH 1	DUSK TO DAWN LIGHT	(2) #12	(1) #12	EMBEDDED IN GENERATOR PAD, BURIED CONDUIT, EXPOSED CONDUIT
15	3/4"	LP-4 TRANSFORMER/PANELBOARD	LIGHT SWITCH 2	(2) #12	(1) #12	EXPOSED CONDUIT/RACK
16	3/4"	LIGHT SWITCH 2	LIGHT 1	(2) #12	(1) #12	EXPOSED CONDUIT
17	3/4"	LIGHT 1	LIGHT 2	(2) #12	(1) #12	EXPOSED CONDUIT
18	3/4"	LIGHT 2	LIGHT 3	(2) #12	(1) #12	EXPOSED CONDUIT
19	3/4"	LIGHT 3	LIGHT 4	(2) #12	(1) #12	EXPOSED CONDUIT
20	2"	AUTOMATIC TRANSFER SWITCH	EXISTING SPARE PULL BOX ON PIER 2E	(19) #12, COMM.	(1) #12	EMBEDDED IN GENERATOR PAD, BURIED CONDUIT
21	2" (EXISTING)	EXISTING SPARE PULL BOX ON PIER 2E	NEW TERMINAL BOX ON EAST TOWER PIER	(19) #12, COMM.	(1) #12	
22	EXISTING CABLE TRAY	NEW TERMINAL BOX ON EAST TOWER PIER	CONTROL HOUSE, PLC PANEL	(20) #12 CABLE		
23	EXISTING CABLE TRAY	NEW TERMINAL BOX ON EAST TOWER PIER	CONTROL HOUSE, CONTROL CONSOLE	COMM. CABLE		FOR REMOTE GENERATOR ANNUNCIATOR DISPLAY, PER GENERATOR MANUFACTURER
24	2"	AUTOMATIC TRANSFER SWITCH	GENERATOR	CONTROLS, COMM.		GENERATOR CONTROLS, PER MANUFACTURER, NOTE 1
25	1"	AUTOMATIC TRANSFER SWITCH	LOAD BANK	(2) #12		CONTROLS, NOTE 1

NOTES:

1. THE CONTRACTOR SHALL PROVIDE CONTROL CONDUCTORS AND COMMUNICATIONS CABLES AS REQUIRED BY EQUIPMENT MANUFACTURERS AND SHALL UPSIZE CONDUITS ACCORDINGLY.

PROJECT NO. 15B.13.28
NEW HANOVER COUNTY

STATION: _____

SHEET 15 OF 16

STATE OF NORTH CAROLINA
 DEPARTMENT OF TRANSPORTATION
 RALEIGH

CAPE FEAR MEMORIAL
 LIFT BRIDGE
 CONDUIT SCHEDULE - 2

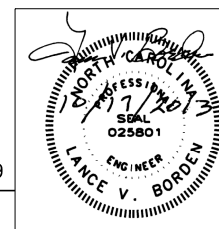

DRAWN BY : RLR DATE : 10/17/2013
 CHECKED BY : JGS DATE : 10/17/2013

10/18/2013 10:32:42 AM
 P:\2986.11\CADD\Electrical\15-E14-CONDUIT SCHEDULE - 2.dgn

DWG NUMBER E14 TOTAL DWGS 16

REVISIONS						SHEET NO.
NO.	BY:	DATE:	NO.	BY:	DATE:	15
1			3			TOTAL SHEETS
2			4			16

GROUP 100 EQUIPMENT

PIECE NO.	QUANTITY	NAME	MANUFACTURER	TYPE - MODEL	RATING AND DESCRIPTION
E101	1	SERVICE DISCONNECT	SQUARE-D	CLASS 3110	HEAVY DUTY FUSED SAFETY SWITCH, RATED FOR USE WITH 480/277 VOLT, 3 PHASE, 4 WIRE, 600A SERVICE. SHALL BE U.L. LISTED WITH NEMA 4X STAINLESS STEEL ENCLOSURE. FUSES SHALL BE 600A, CLASS R. SWITCH OPERATING HANDLE SHALL BE PADLOCKABLE. ASSEMBLY SHALL BE RATED FOR 200,000 RMS SYMMETRICAL AMPERES AVAILABLE FAULT CURRENT. MOUNTING HARDWARE SHALL BE STAINLESS STEEL.
E102	1	GENERATOR	CUMMINS POWER GENERATION	300KW	DIESEL GENERATOR SET, U.L. LISTED 480Y/277 VAC. 3-PHASE, SOLIDLY GROUNDED, 300KW (375 KVA) STANDBY, 60 HZ. 105C RISE ALTERNATOR. PMG EXCITATION, WITH COOLANT, CONTROL PANEL, AND ALTERNATOR HEATERS, BATTERY CHARGER, ELECTRONIC CONTROL SYSTEM, MAIN LINE CIRCUIT BREAKER, 600 GALLON DUAL WALL SUB-BASE FUEL TANK. 150 MPH WIND RATED ALUMINUM, SOUND ATTENUATE LEVEL 2 ENCLOSURE WITH INTEGRATED MUFFLER, REMOTE STATUS PANEL AND NEMA 12 ENCLOSURE.
E103	1	AUTOMATIC TRANSFER SWITCH	CUMMINS POWER GENERATION	OTPC	AUTOMATIC TRANSFER SWITCH, U.L. LISTED. DELAYED TRANSITION, 480 VAC, 3-PHASE, 60 HZ, 3 POLE, 600A. 200KA WITHSTAND AND CLOSE RATING AT 480 VAC WITH CLASS L FUSE PROTECTION. OPEN TRANSITION/ PROGRAMMED, DIGITAL DISPLAY, RELAY SIGNAL MODULE, NEMA 4X ENCLOSURE, RETRANSFER INHIBIT TERMINAL BLOCK.
E104	1	LP-4	SQUARE-D	MINI-POWER ZONE	TRANSFORMER/PANELBOARD COMBINATION UNIT, 15 KVA, SINGLE PHASE, 480V PRIMARY, 240/120V SECONDARY, 24 SPARES, NEMA 3R ENCLOSURE, PRIMARY BREAKER AND SECONDARY MAIN BREAKERS, 65,000A RMS SYMMETRICAL SHORT CIRCUIT INTERRUPTING CAPACITY, COPPER BUS, CONFIGURED FOR BOLT-ON STYLE BREAKERS, BRANCH CIRCUIT BREAKERS AS SHOWN IN THE PLANS.
E105	1	LOAD BANK	AVTRON OR SIMPLEX		STATIONARY RESISTIVE TYPE LOAD BANK, UL LISTED, NEMA 3R ENCLOSURE, 480 VAC, THREE PHASE, 60 HZ, CONTINUOUS DUTY, 50 KW RESOLUTION LOAD STEPS, 200 KW CAPACITY WITH CURRENT TRANSFORMER AND AUTOMATIC SENSING CONTROLS.
E106	4	POWER SPLICER BLOCKS	MARATHON		HEAVY DUTY POWER SPLICER BLOCK, UL RECOGNIZED 600 VAC, RATED FOR COPPER WIRE 760A, 3 POLE, 2 CONNECTIONS PER POLE LINE SIDE AND LOAD SIDE, 500 KCMIL TO #4 AWG WIRE RANGE, WITH CLEAR PLASTIC PROTECTIVE COVER AND MARKING STRIP.
E107	1	PRECAST PULL BOX	QUARITE-HUBBEL	PG	PRECAST POLYMER CONCRETE UNDERGROUND BOX, TIER 15, HEAVY DUTY FLUSH COVER, MINIMUM SIZE AS SHOWN ON THE PLANS, MINIMUM DESIGN LOAD OF 22,500 LBS.

GROUP 200 EQUIPMENT

PIECE NO.	QUANTITY	NAME	MANUFACTURER	TYPE - MODEL	RATING AND DESCRIPTION
E201	2	INTERPOSING RELAY	ALLEN BRADLEY	700 SERIES	PLUG IN TYPE AND BASE, 120 VAC COIL, MOUNT STYLE AND TYPE SHALL MATCH EXISTING INSTALLED RELAYS IN EXISTING PLC PANEL.
E202	1	TERMINAL BOX	CUSTOM		NEMA 4X RATED STAINLESS STEEL ENCLOSURE, CONTINUOUS HINGE, WITH INTERNAL BACKPANEL AND UL LISTED FINGER SAFE TERMINAL BLOCKS RATED AT 300V, SIZED AS REQUIRED BY THE NEC.

GROUP 300 EQUIPMENT

PIECE NO.	QUANTITY	NAME	MANUFACTURER	TYPE - MODEL	RATING AND DESCRIPTION
E301	2	LIGHT SWITCH	HUBBELL	HBL1221BLK	HEAVY DUTY SPECIFICATION GRADE, AC SWITCH. U.L. LISTED, 120/277 VAC, 20A. SINGLE POLE. WITH CORROSION RESISTANT AND WEATHERPROOF CAST ALUMINUM DEVICE BOX AND GASKETED COVER PLATE RATED FOR OUTDOOR AREAS.
E302	4	GFCI DUPLEX RECEPTACLE	HUBBELL	GF5362GYA	HEAVY DUTY SPECIFICATION GRADE, DUPLEX AC GFCI RECEPTACLE U.L. LISTED, 120 VAC, 20A, NEMA 5-20R. WITH CORROSION RESISTANT AND WEATHERPROOF CAST ALUMINUM DEVICE BOX AND GASKETED COVER PLATE RATED FOR OUTDOOR AREAS.
E303	1	DUSK TO DAWN LUMINAIRE	HUBBELL	DDS	DUSK TO DAWN SECURITY TYPE AREA LUMINAIRE. U.L. LISTED FOR WET LOCATIONS. 120 VAC. 150W HIGH PRESSURE SODIUM LAMP. CAST ALUMINUM HOUSING AND CURVED MOUNTING ARM. TWISTLOCK PHOTO-CONTROL.
E304	4	OUTDOOR FLOODLIGHT LUMINAIRE	COOPER	ASF	SLIPFITTER MOUNT FLOODLIGHT, UL LISTED FOR WET LOCATIONS, 120 VAC, 100 W, HIGH PRESSURE SODIUM, POWDER COATED ALUMINUM HOUSING, ADJUSTABLE FOR ANGLE, TYPE 6 x 5 BEAM SPREAD, WITH LAMP, FUSE, AND WIRE LENS GUARD.
E305	2	FIRE EXTINGUISHER	AMEREX		20 LB. ABC TYPE DRY CHEMICAL FIRE EXTINGUISHER, USCG APPROVED, CORROSION RESISTANT HOT DIPPED GALVANIZED DRAWN STEEL CYLINDER WITH POLYESTER POWDER PAINT, -65 TO +120 DEGREE F TEMPERATURE RANGE WITH WEATHERPROOF FIRE EXTINGUISHER CABINET.

DRAWN BY : RLR DATE : 10/17/2013
 CHECKED BY : JGS DATE : 10/17/2013

10/18/2013 10:33:03 AM
 P:\2986.11\CADD\Electrical\16-E15-ELECTRICALEQUIPMENT LIST.dgn

NOTES:

1. THESE EQUIPMENT SCHEDULES DO NOT PROVIDE AN EXHAUSTIVE LISTING OF ALL EQUIPMENT REQUIRED.
2. THE CONTRACTOR SHALL COORDINATE THE EXACT SIZES OF CIRCUIT BREAKERS, FUSES, CONTACTORS, OVERLOAD RELAYS, AND CONDUCTORS, WITH THE SUPPLIERS OF THE EQUIPMENT (MOTORS, ETC.) SERVED.
3. THE CONTRACTOR SHALL CONFIRM ALL QUANTITIES AND THE AVAILABILITY OF ALL SPECIFIED ITEMS.

PROJECT NO. 15B.13.28
 NEW HANOVER COUNTY

STATION: _____

SHEET 15 OF 16

STATE OF NORTH CAROLINA
 DEPARTMENT OF TRANSPORTATION
 RALEIGH

CAPE FEAR MEMORIAL
 LIFT BRIDGE
 ELECTRICAL EQUIPMENT LIST

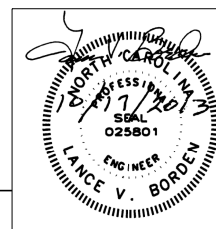

DWG NUMBER	TOTAL DWGS
E15	16

REVISIONS						SHEET NO.
NO.	BY:	DATE:	NO.	BY:	DATE:	16
1			3			TOTAL SHEETS
2			4			16